



401N series
Double Eccentric
Butterfly Valves

OUR PRODUCTION



501M series - Triple Eccentric Metal Seated Butterfly Valves

401N series - Double Eccentric Butterfly Valves

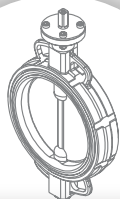

301 / 301E series - Butterfly Valves with rubber seat

301TSS / 301TT series - Butterfly Valves with PTFE lined

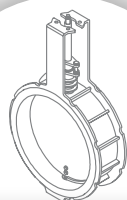

HT600 series - Damper valves for high temperature

AP / APM series - Pneumatic Rotary Actuators

APG series - Schotch Yoke Pneumatic Actuators

S10 series - Wafer Flat Body Ball Valves

S20 series - Two-pieces 800 p.s.i. Ball Valves

S30 series - Split Body Ball Valves

S40, S50, S60, S70, S80 series - Threaded actuated and manual ball valves

MBX Series - Limit Switch Box

SVS Series - Solenoid valve 5/2 or 3/2 way

ACCESSORIES



Sirca International SpA was founded in the late seventies, and started doing business as a manufacturer of complete automation and pneumatic regulation systems.

Our flagship product is rotating pneumatic quarter-turn actuators which are compact, lightweight and highly reliable.

Subsequently, our company entered the Italian market with the production and sale of rubber-seated butterfly valves, double eccentric butterfly valves, ball valves and check valves.

In time at Sirca International we began marketing and producing accessories to actuate, control and regulate valves. These were installed on our own valves and actuators in order to offer our customers complete “assemblies” that are capable of meeting the most varied system requirements.

Beginning in the 1990s, our company began looking at foreign markets and in a short time we started exporting more than 60% of our production.

This type of market development requires continuous product innovation as well as continuous effort to maintain product competitiveness and quality.

With this motivation and these objectives, with the arrival of the new millenium we at Sirca International began designing and producing the triple eccentric butterfly valve metal-seated that are currently top of the range of the valves produced at Sirca.

The main strong points of Sirca International SpA lie in our product quality, competitive price, large warehouse stocks and in the reliability of our services. These confirm our status as a Leading Company on the national and international markets.

INTRODUCTION: Double Eccentricity Butterfly Valve Series 401N

This is a new range of butterfly valves of the double eccentricity type with “bubble tight” seal, designed for heavy duty service, especially as regards to shipbuilding and petrochemical sectors.

Above all it is ideal for shut-off and/or flow control of aggressive fluids or gases.

A wide variety of materials can be used to make the valve; those falling in the standard range are.

- Ductile Iron (only from ND350 and bigger size)
- Carbon Steel
- Stainless Steel
- Aluminium Bronze (only on request)

Such valves are manufactured according to the most up-to-date design criteria, thereby offering maximum guarantee of correct operation and minimum maintenance.

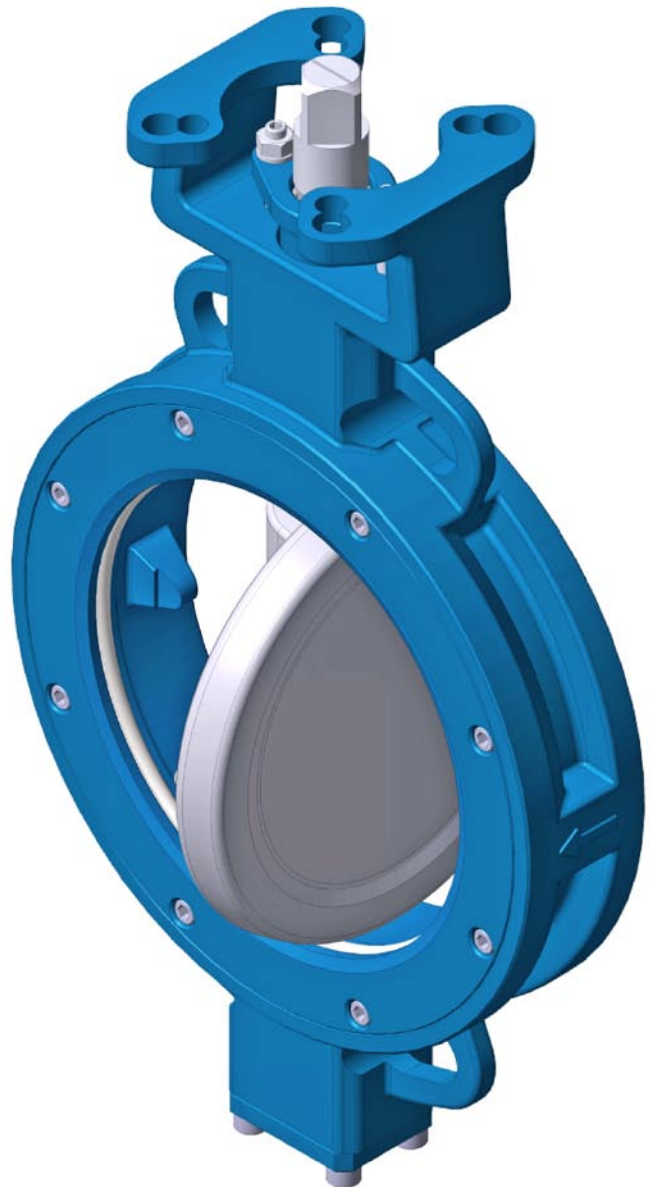
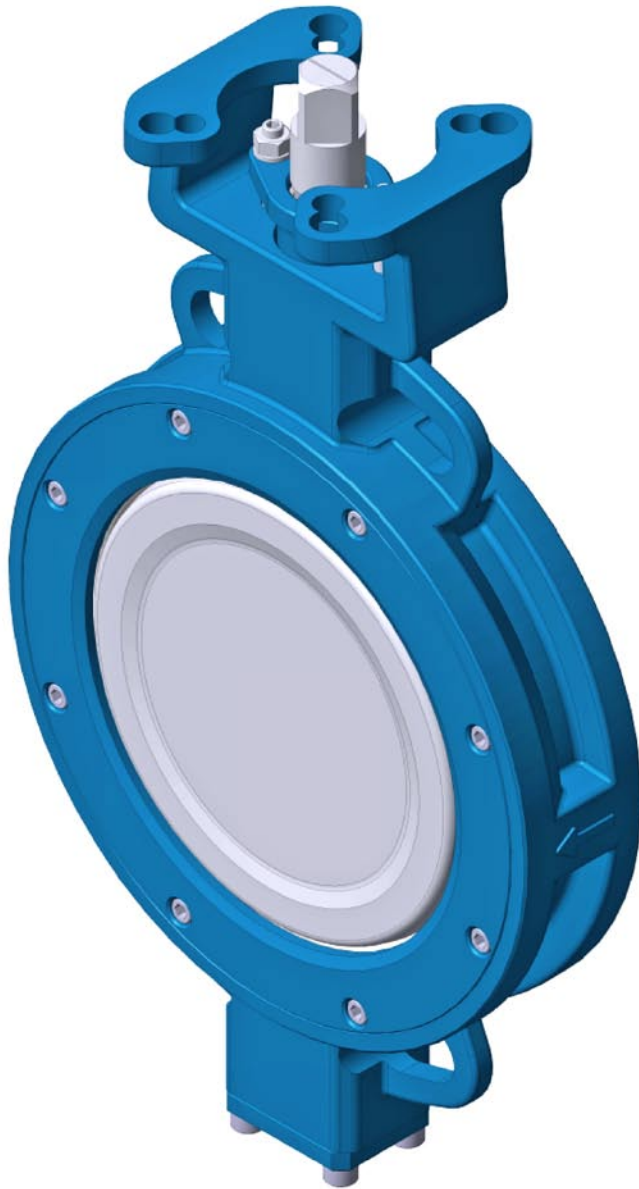

The valve body is of WAFER type with 4 centering holes for facilitating the mounting between the flanges or else of LUG type with threaded or through lugs when the valve is to be used as a foot valve.

The butterfly disc is of the double eccentricity type. This design feature ensures a particularly favourable affect either for flow control or in the opening and closing movement. In fact, the butterfly disc has two surfaces which are different from the degree of the valve opening. This results in a moment of rotation which prevents any possible valve floating.

The seal on the upper stem of the adjustable type and consist of a CHEVRON pack mode of P.T.F.E. + Carbographe, on which a stuffing box acts. When the stem seal requires replacement, such operation can be performed without having to remove the valve from the piping.

The stem is made from 'h8' ground bar, and besides being guided by c.s. + P.T.F.E. or s.s. + P.T.F.E. PAP bushings, it guarantees a perfectly tight shutt-off on the stuffing box. The stem is integral with the butterfly disc through parallel key and tapered pins. A plug with P.T.F.E. O-ring ensures perfectly tight seal on the lower stem.

The seat retaining ring is embedded in the body, according to API 609, and it serves to keep the valve seat in its place. A phonographic groove is machined on the outside of the ring to ensure tight shutt-off between the valve and the flange through a common seal.

The seat is a drop-shaped section solid P.T.F.E. + Carbographe profile, which is in direct contact with the process fluid. Thanks to this solution, the seat can be replaced without having to fully disassemble the valve from the piping.

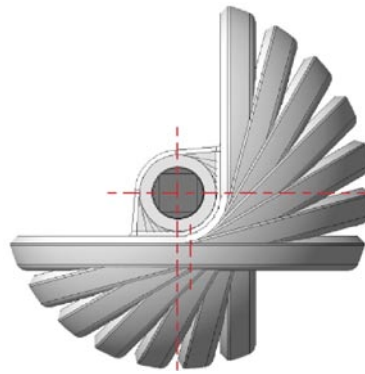

Double eccentricity

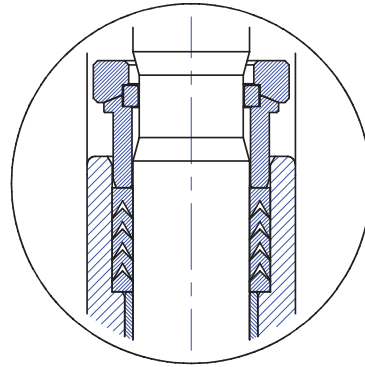

ANTI-BLOWOUT system according to API 609

Seal on the upper stem of adjustable type, it consists of a CHEVRON pack mode of P.T.F.E. + Carbographe on which a stuffing box acts.

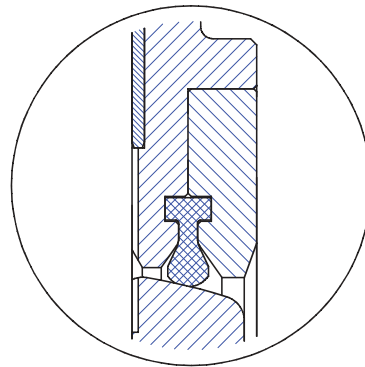

Ring Seat incorporated in valve body according to API 609

P.T.F.E. + Carbographe seat.

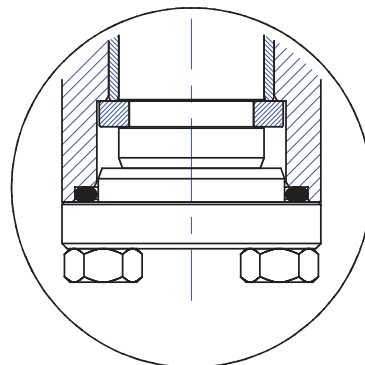

Plug with P.T.F.E. O-ring to ensure a perfect tight on the lower stem

General features

- Manufactured in the diameters from ND80 to ND1400
- Operating temperature: -50°C +200°C
- Mounting between UNI-ISO-DIN PN10-PN16- ANSI150RF flanges.
- Perfect tight shut-off with differential pressure of 21,5 bar under vacuum
- Outer valve parts protected against corrosion (epoxy or polyurethane paint)
- Low static torque
- It can be actuated by:
 - 10 position irreversible leverlock handle
 - Reduction gears with handwheel
 - Pneumatic rotary actuators
 - Electrical actuators

Main fields of application

- ➔ PHARMACEUTICAL INDUSTRIES
- ➔ CHEMICAL INDUSTRIES
- ➔ FOOD INDUSTRIES
- ➔ BREWERIES
- ➔ DISTILLERIES
- ➔ SHIPBUILDING
- ➔ PETROLCHEMICAL



Only from ND350 and bigger size

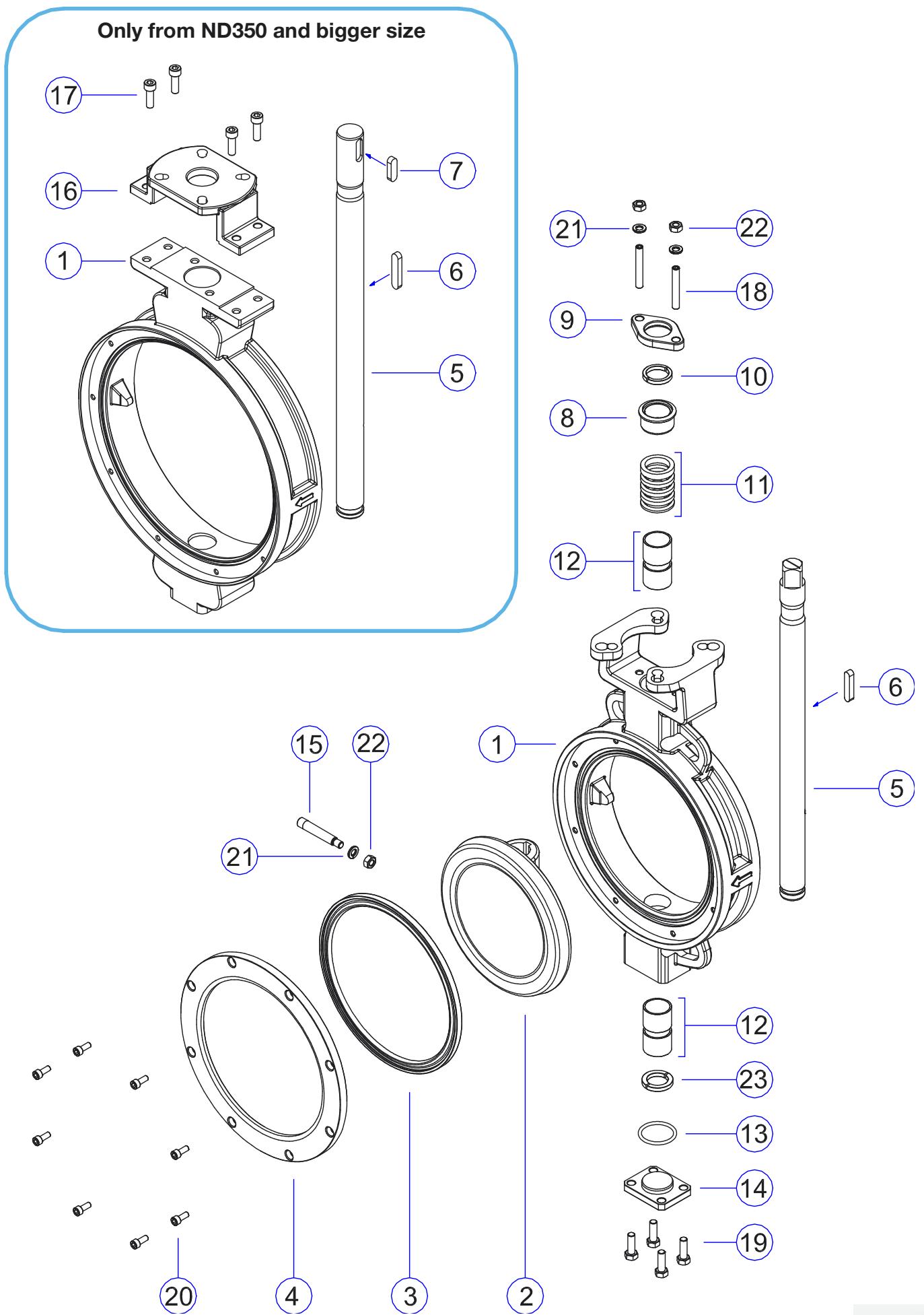

Standard materials

Carbon Steel Configuration

Item	Description	Materials
1**	Body	Carbon Steel ASTM A215 gr. WCB Carbon Steel S355J2 EN10210 or similar Ductile Iron EN GJS 400/15
2**	Disc	Carbon Steel ASTM A215 gr. WCB Carbon Steel S355J2 EN10210 or similar Ductile Iron EN GJS 400/15
3*	Seat	Seat PTFE + Carbographe
4**	Ring Seat	Carbon Steel S355J2 EN10210 or similar
5**	Stem	Stainless Steel AISI 420
6	Disk Key	Stainless Steel AISI 316
7	Upper Key	Stainless Steel AISI 316
8	Stuffing Box Gland	Nichel-Plated Carbon Steel
9	Stuffing Box Plate	Nichel-Plated Carbon Steel
10	Anti-Blowout Ring	Stainless Steel AISI 316
11*	Stuffing Box	PTFE + Carbographe
12	Bushing PAP	Carbon Steel + PTFE
13	Thrust Ring	Stainless Steel AISI 316
14**	Plug	Carbon Steel
15**	Tapered Pin	Stainless Steel AISI 316
16	Bracket	Ductile Iron EN GJS 400/15
17	Screw	Carbon Steel 8.8 Galvanized
18	Stuffing Box Screw	Carbon Steel 8.8 Galvanized
19	Screw	Carbon Steel 8.8 Galvanized
20	Screw	Carbon Steel 8.8 Galvanized
21	LockWasher	Galvanized Carbon Steel
22	Nut	Galvanized Carbon Steel
23*	O-Ring	PTFE

* Spare parts suggested
** Other materials on request

Stainless Steel Configuration

Item	Description	Materials
1**	Body	Stainless Steel ASTM A351 gr. CF8M
2**	Disc	Stainless Steel ASTM A351 gr. CF8M
3*	Seat	PTFE + Carbographe
4**	Ring Seat	Carbon Steel S355J2 EN10210 or similar Stainless Steel ASTM A351 gr. CF8M
5**	Stem	Stainless Steel AISI 316 Stainless Steel AISI 630
6	Disk Key	Stainless Steel AISI 316
7	Upper Key	Stainless Steel AISI 316
8	Stuffing Box Gland	Stainless Steel AISI 316
9	Stuffing Box Plate	Stainless Steel AISI 316
10	Anti-Blowout Ring	Stainless Steel AISI 316
11*	Stuffing Box	PTFE + Carbographe
12	Bushing PAP	Stainless Steel AISI 316 + PTFE
13	Thrust Ring	Stainless Steel AISI 316
14**	Plug	Stainless Steel AISI 316
15**	Tapered Pin	Stainless Steel AISI 316
16	Bracket	Stainless Steel ASTM A351 gr. CF8M
17	Screw	Stainless Steel A2
18	Stuffing Box Screw	Stainless Steel A2
19	Screw	Stainless Steel A2
20	Screw	Stainless Steel A2
21	LockWasher	Stainless Steel A2
22	Nut	Stainless Steel A2
23*	O-Ring	PTFE

* Spare parts suggested
** Other materials on request

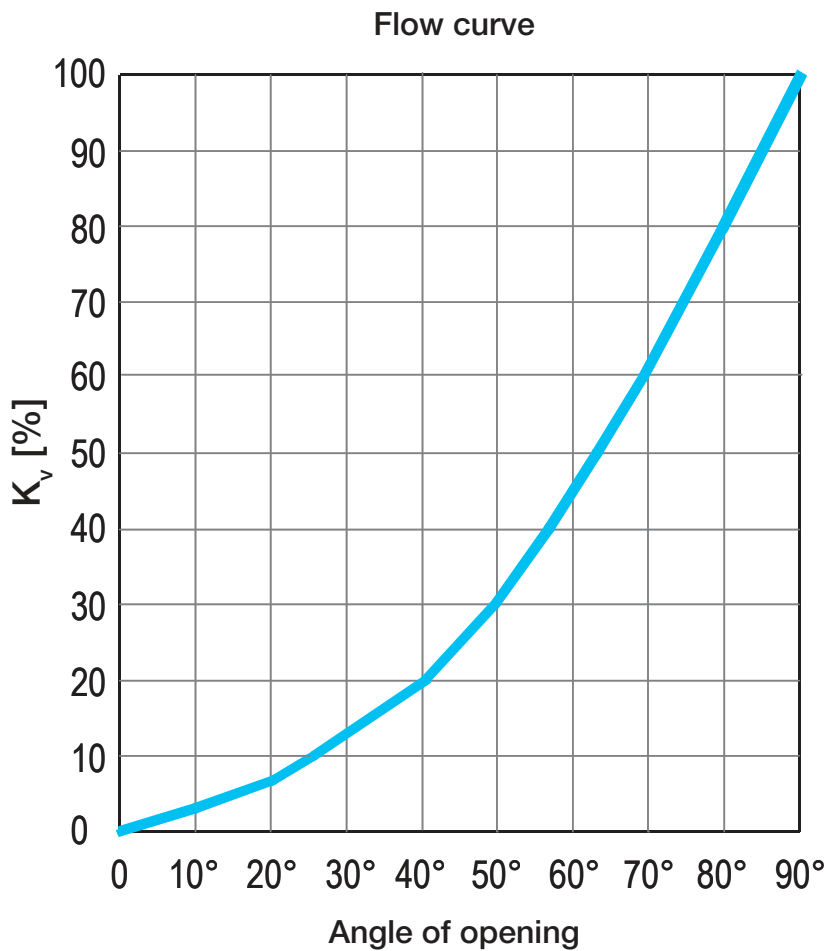

To correctly select the S401N butterfly valve to be used, you have to consider, besides the working conditions (pressure, temperature, medium) the passage conditions offered by the valve itself compared with the medium, so as to optimize the process conditions.

This passage is given by the flow coefficient (CV or K_v) which is a pure number and allows to calculate the capacity that can pass through the valve and/or the pressure loss following the working conditions and the involved mediums.

Flow coefficient K_v [m³/h]

DN		Disc opening tilt								
mm	inc	10°	20°	30°	40°	50°	60°	70°	80°	90°
80	3	3,3	13	30	54	83	119	162	211	219
100	4	6,5	26	60	109	163	236	321	415	429
125	5	10,3	42	95	171	258	372	508	660	679
150	6	15,7	63	146	264	399	578	789	1017	1050
200	8	29	119	276	496	746	1078	1505	1904	1962
250	10	50	200	467	842	1269	1837	2506	3241	3342
300	12	69	276	643	1159	1748	2527	3448	4456	4598
350	14	86	372	868	1564	2357	3412	4653	6204	6517
400	16	125	505	1169	2119	3194	4622	6303	8408	8824
450	18	163	651	1516	3304	4115	5957	8123	10707	10830
500	20	197	787	1835	3680	4982	7211	9833	13110	13699
600	24	300	1197	2795	5029	7494	10974	14967	19955	20949
700	28	456	1848	4304	7790	11595	16991	22895	29688	31616

Pressure drop normograph referred to H₂O

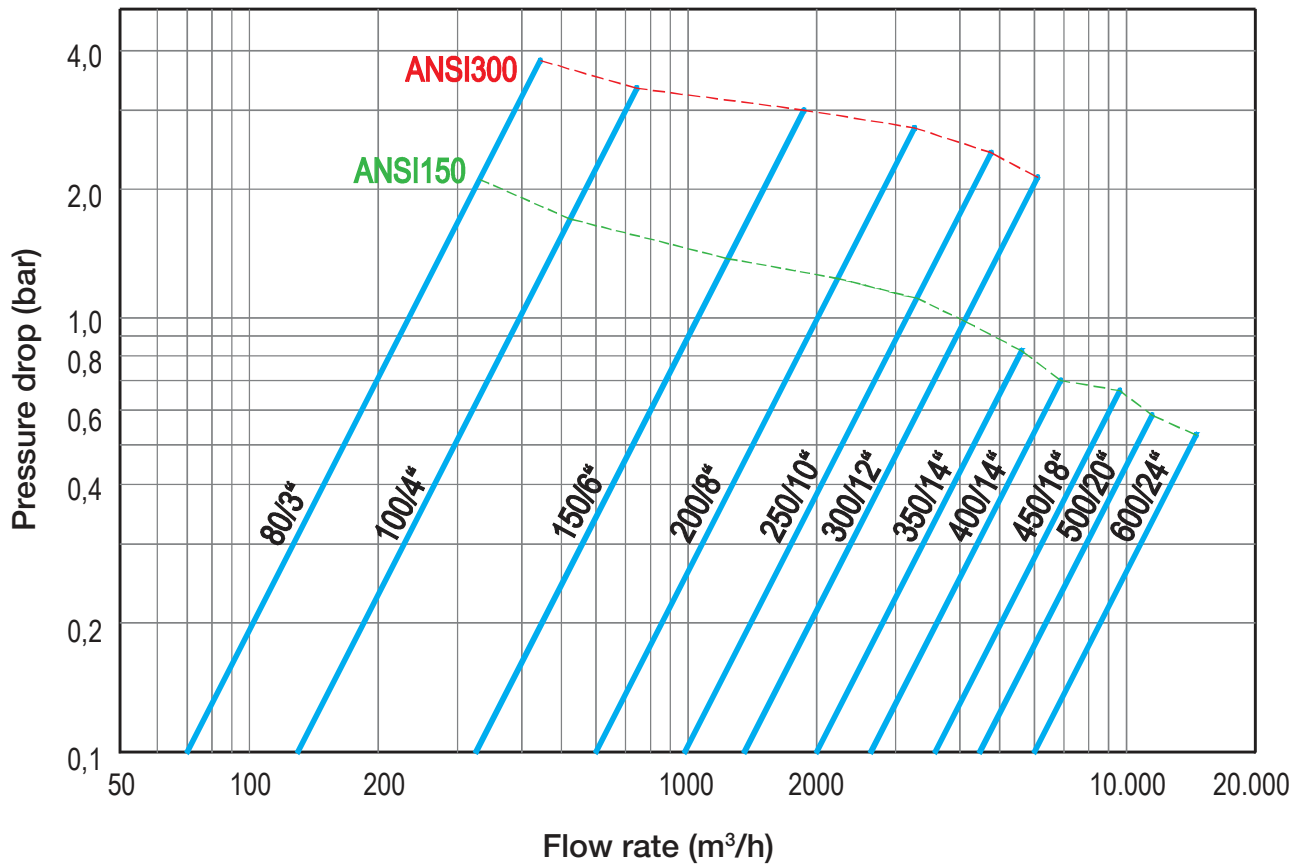

Torque values (Nm)

DN		Pressure [bar]									
mm	inc	0 bar	1 bar	2 bar	3 bar	4 bar	5 bar	PN6	PN10	PN16	ANSI150
80	3	20	-	-	-	-	-	20	25	28	33
100	4	15	-	-	-	-	-	24	30	44	52
125	5	16	-	-	-	-	-	30	45	52	78
150	6	16	-	-	-	-	-	40	56	74	100
200	8	60	-	-	-	-	-	80	110	140	200
250	10	75	-	-	-	-	-	145	190	295	340
300	12	135	-	-	-	-	-	400	400	540	600
350	14	300	350	380	420	470	500	530	680	800	941
400	16	100	355	410	450	525	560	659	845	1083	1388
450	18	200	360	440	480	580	620	30	850	1063	1328
500	20	340	436	559	716	919	1178	1510	1936	2482	3181
600	24	450	577	740	948	1216	1559	1998	2562	3284	4211
700	28	605	735	1000	1282	1644	2107	2702	3464	4441	5693

Weights (Kg)

DN	mm	80	100	125	150	200	250	300
	inc	3	4	5	6	8	10	12
Weight	Wafer	6,8	9	11,2	14,9	22,2	32	44,3
	Lug	9,3	12,4	14,8	19,5	29	42,4	62,9

DN	mm	350	400	450	500	600	700
	inc	14	16	18	20	24	28
Weight	Wafer	71	88,5	125,6	151,8	248,5	373
	Lug	98,3	122,6	174,0	210,2	344,2	516,6

Overall dimensions of S401N butterfly valves ND80÷ND300 WAFER type

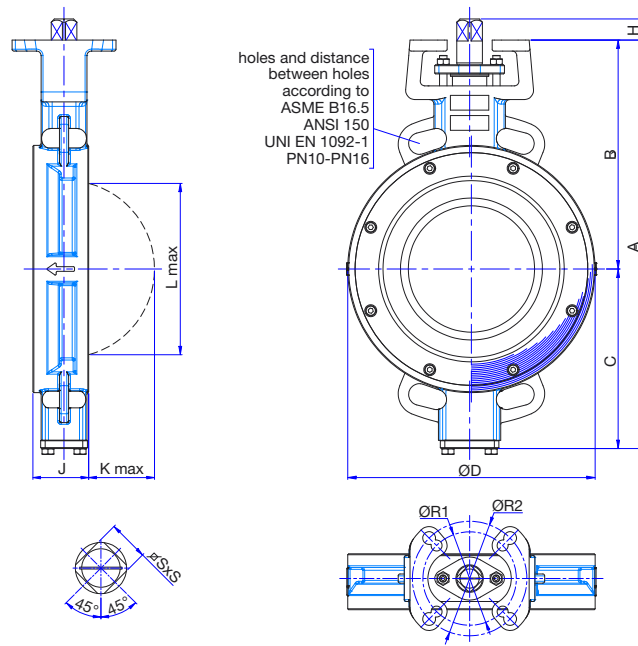

ATTENTION:
DIMENSION "J" in accordance to
UNI EN 558 Basic Series 20

DN		A	B	C	ØD	J	K max	L max	SxS	H	ØR1	ØR2
mm	inc											
80	3	290	171	119	127	46	17,8	62,5	14x14	15	F07	F10
100	4	322	188	134	157	52	28,6	89,2	14x14	15	F07	F10
125	5	343	198,5	144,5	186	56	38,1	113,1	14x14	15	F07	F10
150	6	379	218	161	215	56	51,2	140,4	17x17	18	F10	F12
200	8	447	250	197	270	61	71,8	187,1	22x22	23	F10	F12
250	10	535	302	233	320	68	94,6	236,3	22x22	23	F12	F14
300	12	588	328	260	370	78	116,1	285,9	22x22	29	F12	F14

Overall dimensions of S401N butterfly valves ND350÷ND700 WAFER type

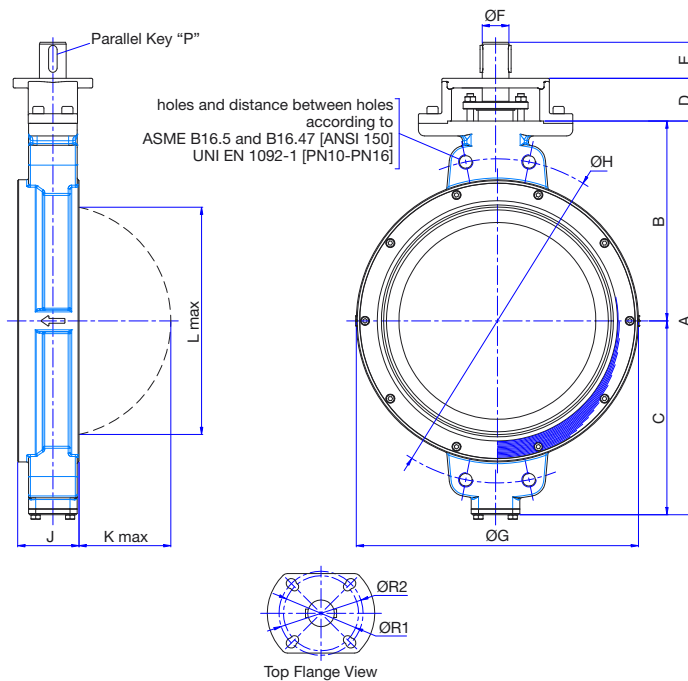

ATTENTION:
DIMENSION "J" in accordance to
UNI EN 558 Basic Series 20
ONLY FOR DN350
dimension "J" in accordance to
UNI EN 558 Basic Series 25

DN		A	B	C	D	ØG	J	K max	L max	E	ØF	P	ØR1	ØR2
mm	inc													
350	14	603	306	297	71	420	92	133	330	60	35	8x7x45	F12	F14
400	16	656	656	323	71	470	102	153	379	60	44,5	14x9x45	F12	F14
450	18	709	709	341	71	532	114	168	426	60	44,5	14x9x45	F12	F14
500	20	774	774	379	71	584	127	196	485	60	44,5	14x9x45	F12	F14
600	24	929	929	457	126	685	154	220	565	90	55	16x10x480	F14	F16
700	28	1057	1057	527	156	795	165	275	665	90	55	16x10x480	F14	F16



Via Trieste n° 8 - 20060 TREZZANO ROSA (MI - ITALY) - Phone ++39 02 92010204
Fax ++39 02 92010216 Purchase Dept. - Fax ++39 02 92011954 Sales Dept.
E-mail: info@sircainternational.com - web site: www.sircainternational.com