

Preparation unit—Accessories

DPS Series digital display pressure switch



Symbol



User interface Instruction

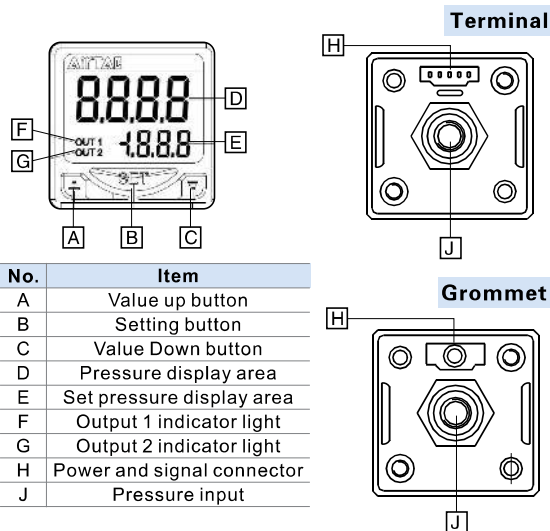

Specification

Input power	Voltage	12~24 VDC ± 10% Ripple(p-p) < 10%
	Fluid	Non-corrosive gas
Pressure range	Measurement range	DPSN1(P1)-01: -100kPa~100kPa
		DPSN1(P1)-10: -100kPa~1,000kPa
	Withstand pressure	DPSN1(P1)-01: 200kPa
		DPSN1(P1)-10: 1500kPa
Measurement error	± 2% F.S. , ± 1digit(Temperature:25 ± 3°C)	
Repetitive accuracy	± 0.2% F.S.	
Temperature error	± 3% F.S.(Base 25°C, Range 0 to 50°C)	
Display	Type	Double row LCD display,4-digit measurement, 3.5-digit setting
	Color	2-color LCD (Red/Green)
	Display period	100ms、250ms、500ms、1,000ms
Output group	DPSN1:Built-in two sets of NPN output	
	DPSP1:Built-in two sets of PNP output	
Transistor output	NPN:Maximum applied voltage 30V/100mA,Retained voltage <1.5V	
	PNP:Maximum applied voltage 30V/100mA,Retained voltage <1.5V	
Response time	2ms、20ms、50ms、100ms、250ms、500ms、1,000ms、2,500ms、5,000ms	
	DPSN1(P1)-01: 0.1、0.2、0.3..... 0.8(kPa)	
Hysteresis	DPSN1(P1)-10: 1、2、3..... 8(kPa)	
	Output mode	
Pressure Unit	DPSN1(P1)-01	kPa、kgf/cm ² 、bar、psi、mmHg、inHg
	DPSN1(P1)-10	MPa、kPa、kgf/cm ² 、bar、psi、cmHg、inHg
Vibration resistance		10 to 500Hz with 10mm Amplitude in X, Y, Z directions for 2hrs
Impact resistance		Maximum 100m/s ² , X, Y, Z directions 3 times each
Operating Temp. range		0~50°C
Stored Temp. range		-20~65°C
Humidity range		35%~80% RH(No condensation)

Ordering code

DPS N1 □ -01 020 □

① ② ③ ④ ⑤ ⑥

① Model	② Output type	③ Electrical entry	④ Measurement range	⑤ Lead wire length	⑥ Piping specifications
DPS: Digital Display Pressure Switch	N1: NPN P1: PNP	Space: Plug-in connector I: Pre-wired type [Note]	01: -100kPa~100kPa 10: -100kPa~1,000kPa	020: Length 2m 030: Length 3m 050: Length 5m	Space: PT 1/8 with M5 female thread T: Male thread NPT1/8; female thread: 10-32UNF G: Male thread G1/8; female thread: M5

[Note] The safety grade of pre-wired type is IP63.

Dimensions

Plug-in connector

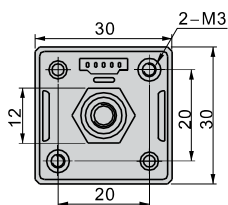

Piping specifications:
Space: PT 1/8 with M5 female thread
T: Male thread NPT1/8; female thread: 10-32UNF
G: Male thread G1/8; female thread: M5

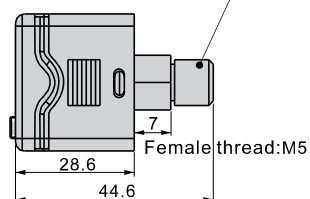

Pre-wired type

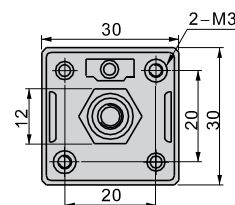

Piping specifications:
Space: PT 1/8 with M5 female thread
T: Male thread NPT1/8; female thread: 10-32UNF
G: Male thread G1/8; female thread: M5

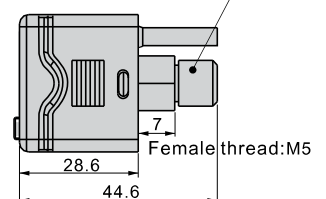

DPS Series digital display pressure switch

User Interface Instructions

1. Mode switch

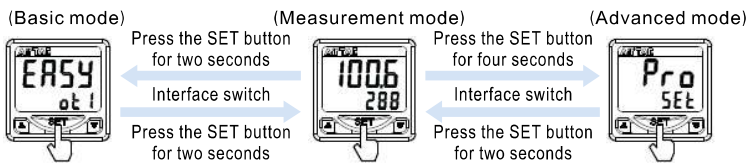

2. Basic mode

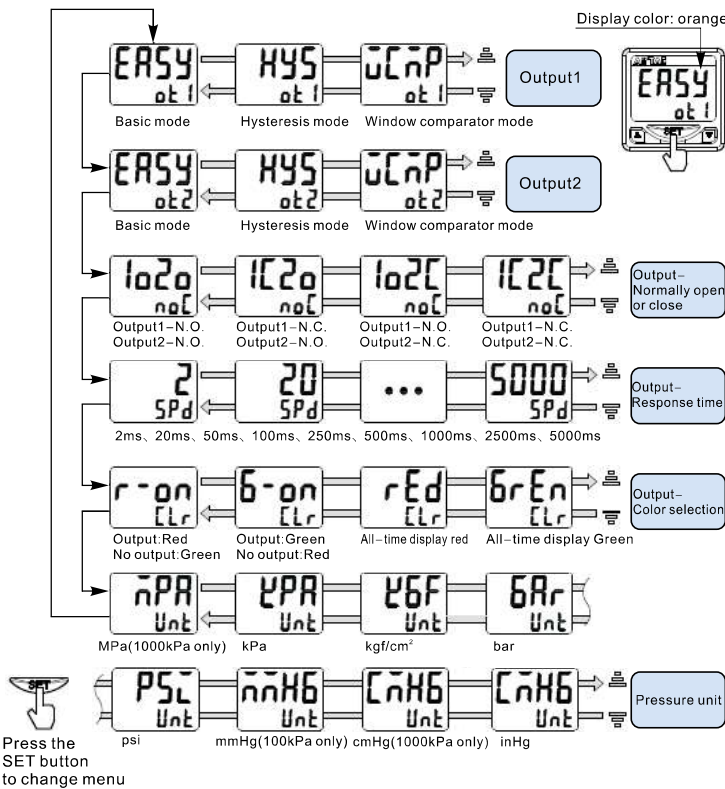

3. Base mode pressure setting

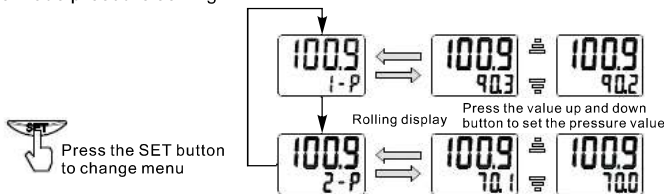

4. Hysteresis /window comparator mode

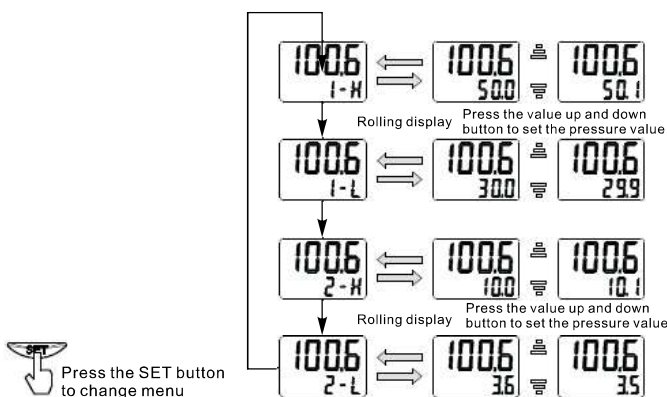

5. Interface of advanced mode

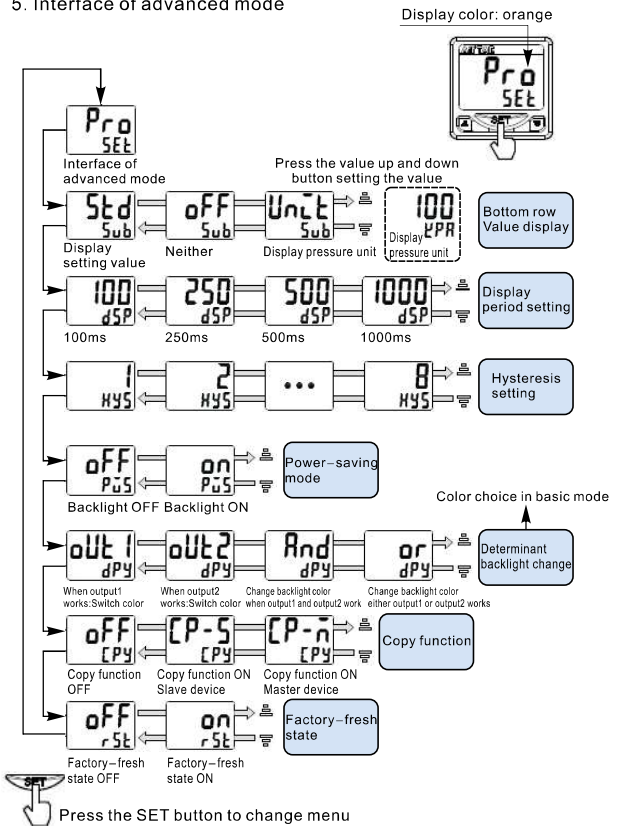

6. Copy function

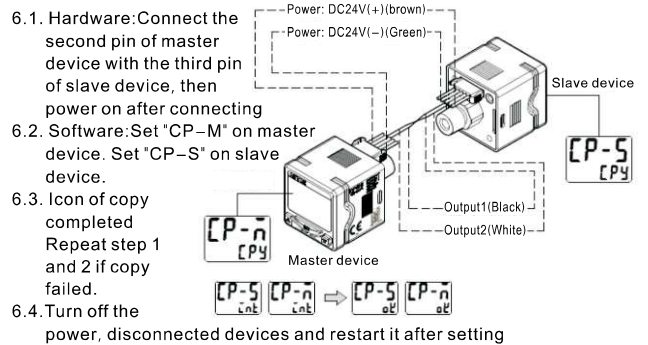

7. Zero-Clear Function

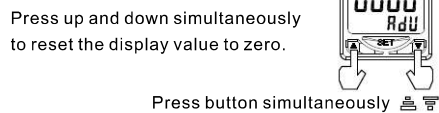

8. Key lock Function

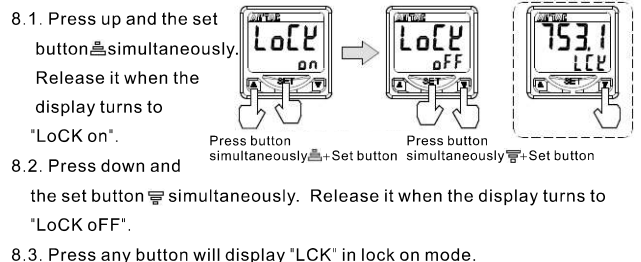

DPS Series digital display pressure switch

Output mode

- 1. Basic mode:** Air pressure setting value 'P'. When air pressure large then (Setting value P+Hysteresis value), the output is 'NO'; When air pressure less than setting value 'P', the output is 'OFF'.

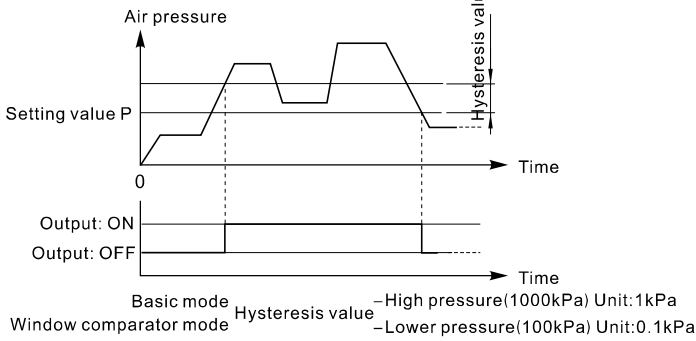

- 2. Hysteresis mode:** Air pressure setting value 'H/L'. When air pressure large then setting value 'H', the output is 'NO'; When air pressure less than setting value 'L', the output is 'OFF'.

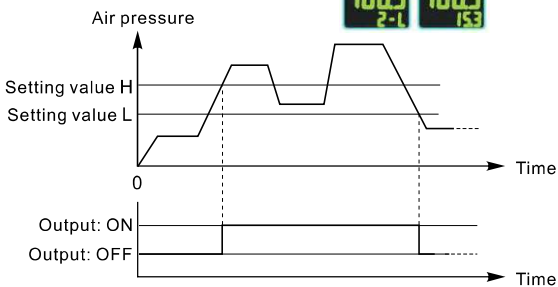
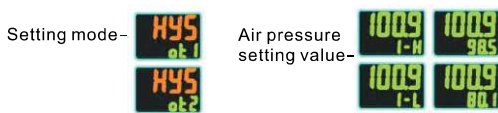

- 3. Window comparator mode:** Air pressure setting value 'H/L'. When air pressure large then value 'H' or less than value 'L', the output is 'OFF'; When air pressure large then value 'L' and less than value 'H', the output is 'ON'.

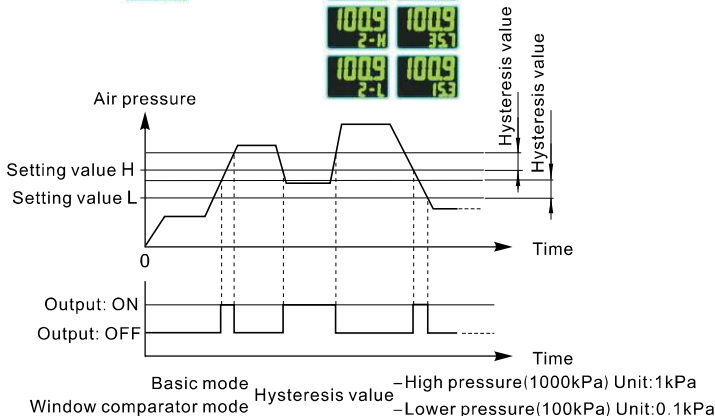

Connection Example

NPN Output

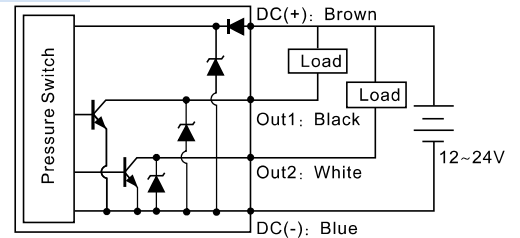

PNP Output

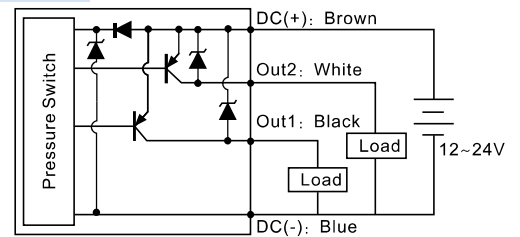

Dimensions/Assembly Instruction

Panel mount adapter + Front protective cover

Order the Install accessories (Ordering code: F-DPSEB)

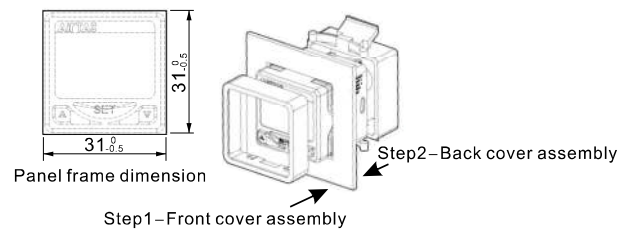

Bracket

Order the Install accessories (Ordering code: F-DPSLB)

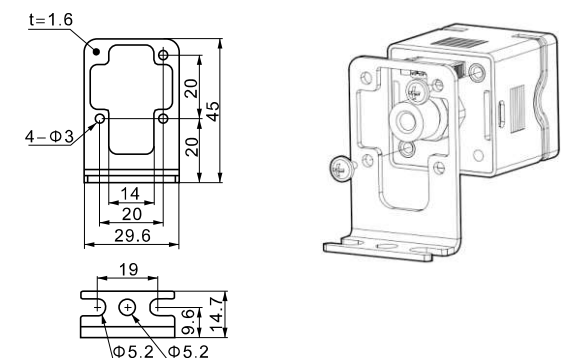

Notes

1. Do not drop · knock or apply excessive impact while handling. Otherwise could cause damage and a malfunction.
2. The tensile strength of the cord is 60N. Applying a greater pulling force on it can cause a malfunction.
3. Do not exceed the screw-in torque of 7N.m when installing piping. Exceeding this value may cause malfunctioning of the sensor.
4. Do not use it with corrosive and/or flammable gases or liquids.
5. Please use it within rated pressure range.
6. Turn off the power before connecting the wires.
7. Don't use in an environment with spattering liquid of oil or solvent.
8. Separate power lines from high voltage lines, avoiding wiring in the same conduit with these lines.

Preparation unit—Accessories

DPC Series minitype no display pressure switch



Symbol



Product feature

1. Larger measurement range. Easy to install.
2. Two lines type or three lines type (NPN/PNP output mode) to be chosen.
3. Single button to finish learning setting. Normally close and normally open can be exchanged.
4. Two kinds of setting mode (Simple mode and middle value mode) to be chosen.

Inner structure

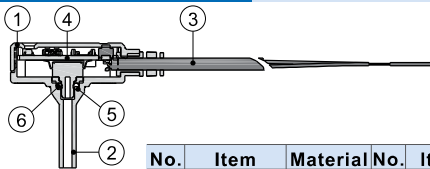

No.	Item	Material	No.	Item	Material
1	Up cover	PC	4	PCBA	
2	Basic seat	PC+ABS	5	Gasket	POM
3	Wire Line	PVC	6	O-ring	NBR

Specification

Item\Model	DPC	DPCN	DPCP
Voltage	DC24V±10%	DC12~24V±10%	
Pressure range	DPC□10: -100kPa~1000kPa; DPC□01: -100kPa~100kPa		
Applied fluid	Air, Non-corrosive gas, Incombustibility gas		
Repetitive accuracy	±0.7%F.S		
Temperature accuracy	±2.5%F.S		
Hysteresis	<2%F.S		
Operating Temp. range	0~60°C		
Output style	5~40mA	30V/100mA Max.	
Voltage drop	5.5V Max.	0.7V Max.	
Method of adjusting pressure	Learning button		
Leakage current	1.0mA Max.		
Stored Temp. range	-20~75°C		
Tube O.D.	Φ4mm, Φ6mm, Φ1/4"		
Special function	Two sets model, NO/NC switch		
Production circuit	Power reverse polarity, surge suppression		
Protection	IP40		

[Note1] Two lines type be used under DC20V, leakage current might excess 1mA to lead PLC damage and error acting.

[Note2] If relay be used as joint points, capacitance(>50V/100uF) should be used to recede leakage current.

Ordering code

DPC □ - □ □ □

① ② ③ ④ ⑤

① Model	② Output type	③ Measurement range	④ Lead wire length	⑤ Tube O.D.
DPC: Minitype no display pressure switch	Blank: Two-lines N: NPN P: PNP	01: -100kPa~100kPa 10: -100kPa~1000kPa	020: Length 2m 030: Length 3m 050: Length 5m	D4: Φ4mm D6: Φ6mm 08: Φ1/4"

Installation and application

1. Connection Example:

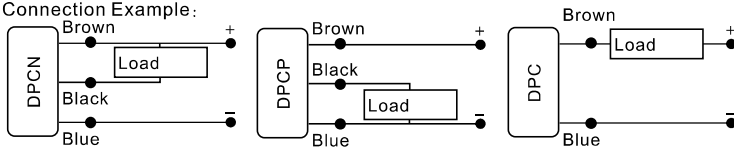

2. Function operation:

- 2.1) Quick setting: Press the SET button for less then two seconds to finish quick setting.
- 2.2) Middle value setting: Press the SET button for two to five seconds to finish setting valve A; Press the SET button again to finish setting valve B. * Middle valve=(A+B)/2 *
- 2.3) N.O./N.C. switch: Press the SET button for six to ten seconds to finish N.O./N.C. switching.
- 2.4) Lock/Unlock switch: Press the SET button for eleven to twenty seconds to finish Lock/Unlock switching.
- 2.5) Factory-fresh state: Press the SET button for over twenty seconds to return factory-fresh state.

3. Notes:

- 3.1) Avoid dropping, beating, impacting which might damage DPC and bring error acting.
- 3.2) Wire line drawing force is 30N, more then this force might damage it.
- 3.3) Causticity or flammability gas and liquid can't be used.
- 3.4) Can't binding with power wire line and higher voltage wire line when wiring.
- 3.5) If use DPC to drive relay, solenoid valve directly which easy create overrun voltage load, the overrun voltage absorb unit should be set.

Use example

Check cylinder pressure

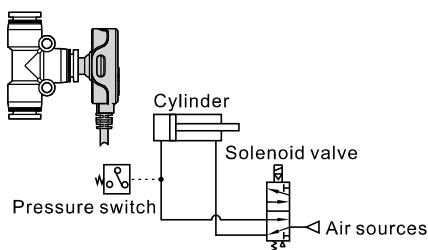

Conform air sources pressure

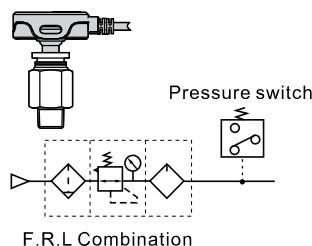

Conform cupula whether sucked

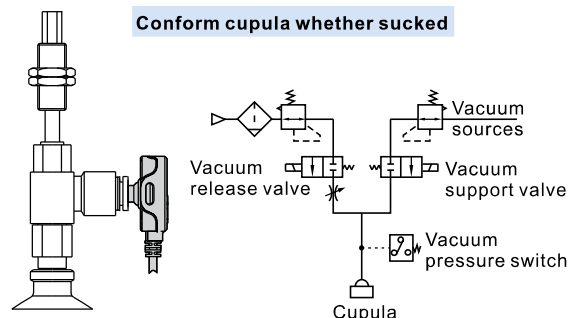

DPC Series minitype no display pressure switch

Cresset explanation

● Invariance light Coruscate quickly(Per 0.1 sec.) Coruscate(Per 1 sec.) Slowness coruscate(Per 3 sec.)

Simple mode			Middle value mode		
Light station	DPC station		Light station	DPC station	
	Red(continuance 1 sec.): N.O. mode Green(continuance 1 sec.): N.C. mode	Finished setting action		Red(continuance 1 sec.): N.O. mode Green(continuance 1 sec.): N.C. mode	Finished setting air pressure value
●	Red N.O. mode, Sense value>Setting value Green N.C. mode, Sense value<Setting value			Red N.O. mode Green N.C. mode	Wait to press
	Red N.O. mode, Sense value<Setting value Green N.C. mode, Sense value>Setting value		●	Red N.O. mode, Sense value>Setting value Green N.C. mode, Sense value<Setting value	
				Red N.O. mode, Sense value<Setting value Green N.C. mode, Sense value>Setting value	
To be continued mode			Overrun caution		
Light station	DPC station		Light station	DPC station	
	Red and green counterchange: DPC wait to set			Red and green alternating coruscate: Overrun caution	

Operation explanation

