



# Air gripper—HFP Series

Mechanical parallel style

## Compendium of HFP Series

**Five kinds of bore size and two kinds of type**

Bore size: 10、16、20、25、32  
HFP: Double acting、HFTP: Single acting and normally opened

**Two kinds of finger type**

Standard type    Thru.hole mounting type(N)

**Structure of lever type gripping**

A structure of lever type gripping is designed to reduce the cost under the premise of accuracy. The finger clamps when the piston rod pushes out and stretches when the piston rod retracts. The gripping force is 20%~30% greater than the tensile force.

**High gripping accuracy**

The contact area between finger and body is enlarged to reduce shaking and enhance the gripping accuracy.

**Anti-abrasion**

A sheet metal is installed between the finger and body to reduce abrasion and extend the service life.

**Can be mounted from two directions**

With mounting holes on the side and tail.

**With magnetic switch slots**

The magnetic switch slots convenient to install inducting switch.

Opened port    Closed port

Surface installation    Tail installation    Front installation

Bore size (mm)		10	16	20	25	32
Acting type		Double acting, Single acting				
Fluid		Air(to be filtered by 40 μ m filter element)				
Operating pressure	Double acting	Φ10	0.2~0.7MPa(28~100psi)(2.0~7.0bar)			
		Others	0.15~0.7MPa(22~100psi)(1.5~7.0bar)			
	Single acting	Φ10	0.35~0.7MPa(50~100psi)(3.5~7.0bar)			
		Others	0.25~0.7MPa(36~100psi)(2.5~7.0bar)			
Proof pressure		1.05MPa(150psi)(10.5bar)				
Temperature °C		-20~70				
Lubrication		Cylinder: Not required; Gripper jaws: Lubricate grease				
Max. gripping length [Note1] mm		30	40	60	70	90
Max. frequency		180(c.p.m)				
Sensor switches [Note2]		CS1-G/DS1-G			CS1-G/DS1-G、DS1-H	
Port size		M3×0.5		M5×0.8		

[Note1] Refer to right graph for the definition of max. gripping length.

[Note2] Sensor switch should be ordered additionally, please refer to P313 for detail of sensor switch.

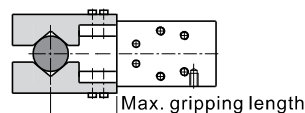

# Air gripper(Mechanical parallel style)

## HFP Series



### Ordering code

**HFP 20**

① ② ③

① Model	② Bore size	③ Finger type
HFP: Air finger(Double acting) (mechanical parallel style)	10 16 20 25 32	Blank: Standard
HFTP: Air finger (Single acting and normally closed) (mechanical parallel style)		N: Thru.hole mounting type

### Symbol

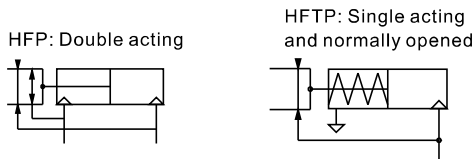

[Note] HFP series are all attached with magnet.

### Inner structure and material of major parts

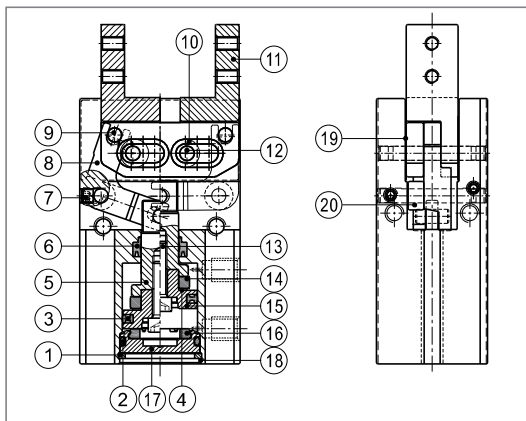

NO.	Item	Material	NO.	Item	Material
1	C clip	Spring steel	11	Gripping jaws	Stainless steel
2	O-ring	NBR	12	Pin	Stainless steel
3	Piston seal	NBR	13	Screw	Carbon steel
4	Magnet washer	NBR	14	Magnet	Sintered metal (Neodymium-iron-boron)
5	Piston rod	Aluminum alloy Stainless steel	15	Piston	Aluminum alloy Stainless steel
6	Rod packing	NBR	16	Bumper	TPU
7	Countersink screw	Carbon steel	17	Back cover	Aluminum alloy
8	Curved bar	Stainless steel	18	Body	Aluminum alloy
9	Pin	Stainless steel	19	Retaining ring	Stainless steel
10	Guide sleeve	Stainless steel	20	Stopper sleeve	Stainless steel

### Installation and application

- Due to the abrupt changes, the circuit pressure is low, which will lead to the decrease of the gripping force and falling of the work-pieces. In order to avoid the harm to the human body and damage to the equipment, anti-dropping device must be equipped.
- Don't use the air gripper under strong external force and impact force.
- When install and fix the air gripper, avoid falling down, collision and damage.
- When fixing the gripping jaw parts, don't twist the gripping jaw.
- There are several kinds of installation method, and the locking torque of fastening screw must be within the prescribed torque range shown in the below chart. If the locking torque is too large, it will cause the dysfunction. If the locking torque is too small, it will cause the position deviation and fall.

#### Tail installation type

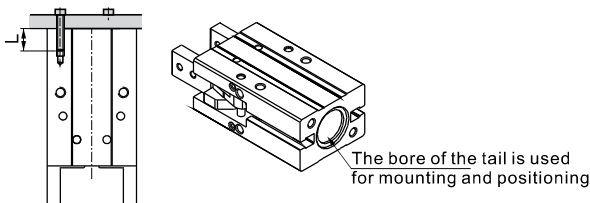

Bore size	The bolts type	Max. locking moment	Max. screwed depth	The aperture of the positioning bore	The depth of the positioning bore
10	M3×0.5	1.0N.m	6mm	Φ11mm <sup>+0.05</sup> <sub>0</sub>	1.0mm
16	M4×0.7	2.0N.m	8mm	Φ17mm <sup>+0.05</sup> <sub>0</sub>	1.2mm
20	M5×0.8	4.5N.m	10mm	Φ21mm <sup>+0.05</sup> <sub>0</sub>	1.2mm
25	M6×1.0	7.0N.m	12mm	Φ26mm <sup>+0.05</sup> <sub>0</sub>	1.5mm
32	M6×1.0	7.0N.m	12mm	Φ34mm <sup>+0.05</sup> <sub>0</sub>	1.5mm

#### The installation of the front threaded hole

Bore size	The bolts type	Max. locking moment(Nm)	Max. screwed depth(mm)
10	M3×0.5	0.7	5
16	M4×0.7	2.0	8
20	M5×0.8	4.5	10
25	M6×1.0	7.0	12
32	M6×1.0	7.0	12

#### Surface installation type

Bore size	The bolts type	Max. locking moment (Nm)	Max. screwed depth (mm)
10	M3×0.5	1.0	6
16	M4×0.7	2.0	8
20	M5×0.8	4.5	10
25	M6×1.0	7.0	12
32	M6×1.0	7.0	12

6. Other contents of installation and operation are the same with those of HFZ. Refer to the "Installation and Operation" instruction of HFZ.

## HFP Series

### How to select product

Please select pneumatic finger according to the following steps:

- ① The selection of the effective gripping force
- ② the confirmation of the gripping point
- ③ the confirmation of the external force put on the gripping jaw

#### 1. The selection of the gripping force

The gripping work-pieces shown below, on the impact condition of ordinary handling state, taking safety coefficient  $a=4$ , have a gripping force that is more than 10-20 times of the mass of the gripped objects.

	The work-pieces as shown in the left : F: Gripping force (N) $\mu$ : friction coefficient between fittings and work-pieces. m: mass of work-pieces g: acceleration of gravity ( $=9.8\text{m/s}^2$ )	The condition that the work-pieces won't drop is: $2 \times \mu F > mg$ so: $F > \frac{mg}{2 \times \mu}$ Safety coefficient is a, so F is: $F = \frac{mg}{2 \times \mu} \times a$	$\mu = 0.2$ $F = \frac{mg}{2 \times 0.2} \times 4 = 10 \times mg$ 10 times of the mass of the gripped objects	$\mu = 0.1$ $F = \frac{mg}{2 \times 0.1} \times 4 = 20 \times mg$ 20 times of the mass of the gripped objects
--	--	---	---	---

Note) If the friction coefficient  $\mu > 0.2$ , for safety, please also select clamping force according to the principle of 10~20 times of the mass of the clamped objects. As for large acceleration and shock, it requires for greater safety coefficient.

1.1) The actual gripping force must be within the effective gripping forces of different pneumatic fingers specifications shown in the below chart.

#### Double acting type closed gripping force

#### Double acting type opened gripping force

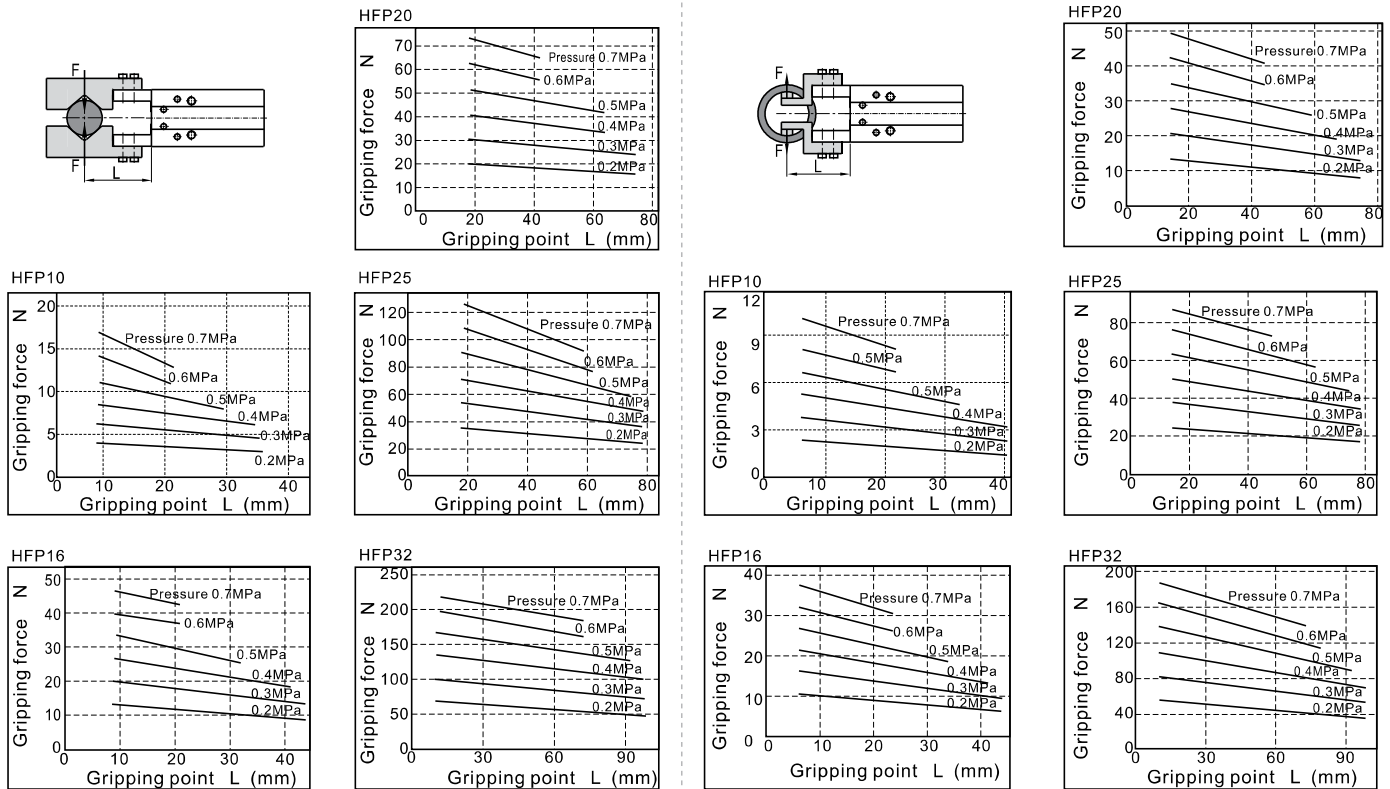

#### 2. The selection of the gripping point

2.1) Select the gripping point within the maximum gripping length range. Over the limits, gripping jaws would be subjected to excessive torque loads, and lead to short life of the air gripper.

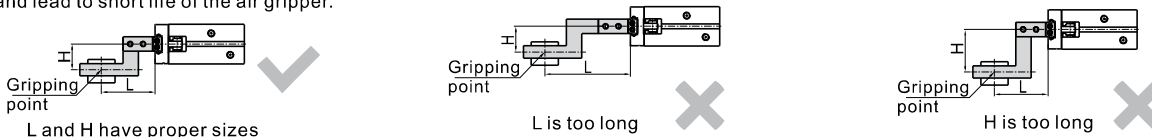

2.2) In the allowable range of gripping point, it is better to design for short and light fittings. If the fittings are long and heavy, the inertia force when the finger is open and close will become larger, and the performance of gripping jaw will be degraded, at the same time it will affect the life.

2.3) When the gripped object is very fine and thin, you have to equip with gap between fittings. If not, there will be unstable clamp, resulting in a position offset and adverse clamping and so on.



# Air gripper(Mechanical parallel style)

## HFP Series

### 3. The confirmation of the external force put on the gripping jaw.

Bore size	The allowed vertical loads Fv(N)	Max. permissible torque(Nm)			The calculation of allowable forces when moment loads work	Examples of calculation
		Mp	My	Mr		
10	58	0.26	0.26	0.53	$\text{Allowable load(N)} = \frac{\text{M(Maximum permissible moment)(N.m)}}{L \times 10^{-3}}$ Unit conversion constant	In the guide rail of HFP16, the external force of the pitching moment static loads put on the point of L=30mm is f=10 N,  Allowable load $F = \frac{0.68}{30 \times 10^{-3}} = 22.7(N)$  Actual load $f=10(N) < 22.7(N)$ To meet the using requirements
16	98	0.68	0.68	1.36		
20	147	1.32	1.32	2.65		
25	255	1.94	1.94	3.88		
32	343	3	3	6		

[Note] The loads and torque values of said are all static values.

## Dimensions

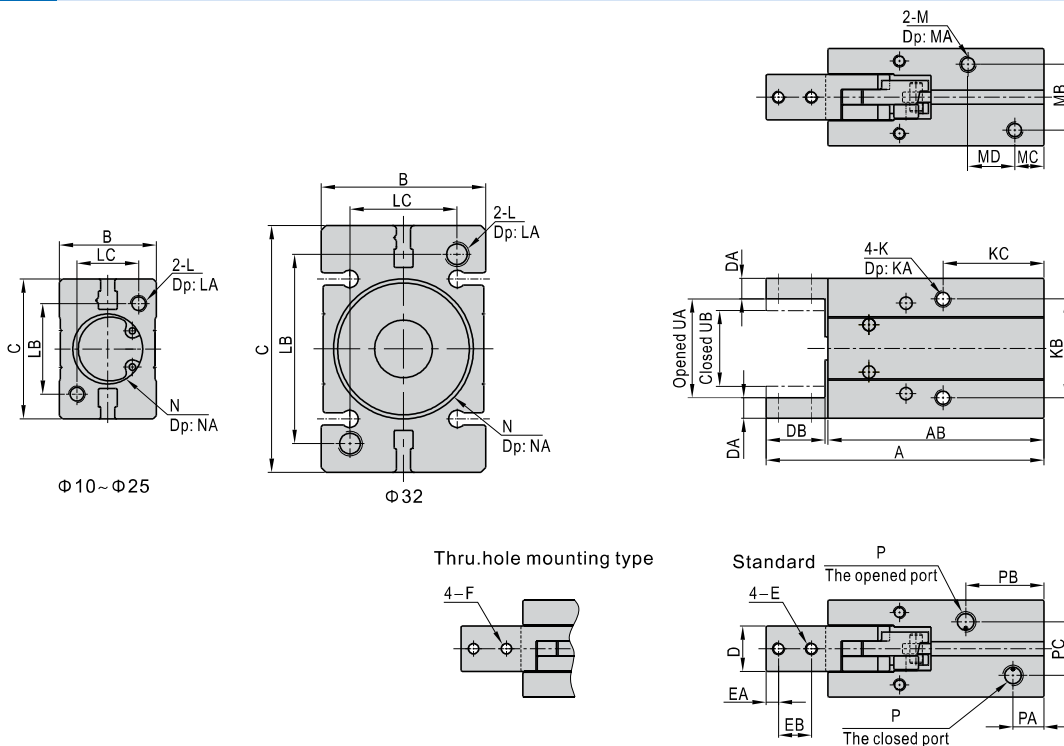

Model\Item	A	AB	B	C	D	DA	DB	E	EA	EB	F	K	KA	KB	KC	L	LA
HFP10	57(62)	44.5(49.5)	16	23	7	4	12	M2.5 × 0.45	3	5.5	Φ2.8	M3 × 0.5	5	16	23(28)	M3 × 0.5	6
HFP16	72(77)	56.5(61.5)	23.5	34	11	5	15	M3 × 0.5	4	7	Φ3.3	M4 × 0.7	8	24	29(34)	M4 × 0.7	8
HFP20	89.5(94.5)	69(74)	27.5	45	12	6	20	M4 × 0.7	5	9	Φ4.5	M5 × 0.8	10	30	34(39)	M5 × 0.8	10
HFP25	104.5(109.5)	78.5(83.5)	33.5	52	14	8	25	M5 × 0.8	6	12	Φ5.5	M6 × 1.0	12	36	31.5(36.5)	M6 × 1.0	12
HFP32	118(126)	88(96)	40	60	18	9	29	M6 × 1.0	7	14	Φ6.5	M6 × 1.0	12	46	37.5(45.5)	M6 × 1.0	12

Model\Item	LB	LC	M	MA	MB	MC	MD	N	NA	P	PA	PB	PC	UA(Opened)	UB(Closed)
HFP10	18	12	M3 × 0.5	6	10	6(11)	10	Φ11 <sup>+0.05</sup>	1	M3 × 0.5	6	16.5(23)	10	14.5 <sup>+1.5</sup>	10.5 <sup>-1</sup>
HFP16	22	15	M4 × 0.7	8	16	6(11)	16	Φ17 <sup>+0.05</sup>	1.2	M5 × 0.8	7.5	20(25)	13	23.5 <sup>+1.5</sup>	15.5 <sup>-1</sup>
HFP20	32	18	M5 × 0.8	10	18	8(13)	16	Φ21 <sup>+0.05</sup>	1.2	M5 × 0.8	7.5	24(29)	15	32.5 <sup>+1.5</sup>	20.5 <sup>-1</sup>
HFP25	40	22	M6 × 1.0	12	24	8(13)	16	Φ26 <sup>+0.05</sup>	1.5	M5 × 0.8	8	22(29)	20	35.5 <sup>+1.5</sup>	21.5 <sup>-1</sup>
HFP32	46	26	M6 × 1.0	12	30	8(16)	20	Φ34 <sup>+0.05</sup>	1.5	M5 × 0.8	9.5	26(37)	22	42 <sup>+1.5</sup>	26.5 <sup>-1</sup>

[Note] The values in "( )" in the above table are single acting type sizes.