

Preparation unit—G Series



GFR Series Filter & regulator



Symbol

No reflux valve is attached



Reflux valve is attached

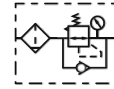

Product feature

1. Embedded square pressure gauge is used to save installation space. (External circular pressure gauge is also optional).
2. The pressed-in self-locking mechanism can prevent the abnormal movement of the set pressure caused by external interfere.
3. Balanced design is adopted for the pressure adjustment mechanism.
4. In addition to standard type, lower pressure type is optional (The highest adjustable pressure is 0.4MPa).
5. Unique diversion structure spins the air flowing through to effectively separate the liquid from the air and reliably filter the solid grain.
6. The filtering grade includes 5 μm and 40 μm (optional).
7. Three drain types are available: manual drain, semi-auto drain and automatic drain.
8. The bracket can be selected for installation.

Specification

Model	GFR200-06	GFR200-08	GFR300-08	GFR300-10	GFR300-15	GFR400-10	GFR400-15	GFR600-20	GFR600-25
Fluid	Air								
Port size [Note1]	1/8"	1/4"	1/4"	3/8"	1/2"	3/8"	1/2"	3/4"	1"
Filtering grade	40 μm or 5 μm								
Pressure range	Semi-auto and automatic drain: 0.15~0.9MPa(20~130psi); Manual drain: 0.05~0.9MPa(7~130psi)								
Max. pressure	1.0MPa(145psi)								
Proof pressure	1.5MPa(215psi)								
Temperature range	-5~70°C(Unfreeze)								
Capacity of drain bowl	10CC			40CC			80CC		230CC
Weight	220g			500g			1030g		2400g

[Note1] PT thread, G thread and NPT thread are available.

Ordering code

GFR200 08 M L □ □ F 1 W G K

① ② ③ ④ ⑤ ⑥ ⑦ ⑧ ⑨ ⑩ ⑪

① Model	② Port size	③ Drain type	④ Type code	⑤ Accessories	⑥ Pressure gauge	⑦ Pressure gauge shape	⑧ Scale	⑨ Filtering grade	⑩ Thread type	⑪ Code of reflux valve [Note2]
GFR200: G200 Series filter-regulator	06: 1/8" 08: 1/4"	Blank: Semi-auto drain M: Manual drain	Blank: Standard L: Lower pressure [Note1]	Blank: Bracket J: No bracket	Blank: Pressure gauge N: No pressure gauge	F: Square C: Circular	1: MPa 2: psi 3: bar	Blank: 40 μm W: 5 μm	Blank: PT G: G T: NPT	Blank: No reverse flow valve is attached K: Reverse flow valve is attached
GFR300: G300 Series filter-regulator	08: 1/4" 10: 3/8" 15: 1/2"	Blank: Semi-auto drain M: Manual drain A: Automatic drain								
GFR400: G400 Series filter-regulator	10: 3/8" 15: 1/2"									
GFR600: G600 Series filter-regulator	20: 3/4" 25: 1"									

[Note1] The maximum work pressure of lower pressure type is 0.4MPa(58psi); [Note2] Please refer to page 173 for details of reflux valve.

Inner structure

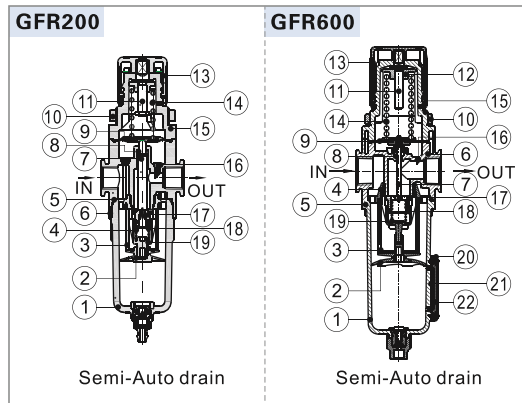

No.	Item	Material	No.	Item	Material
1	Drain bowl	Aluminum alloy(GFR600)\PC(others)	11	Adjusting spindle	Steel
2	Umbrella baffle	High viscosity POM	12	Regulator nut	Steel
3	Filter core	GFR600	13	Pressure knob	POM
		40 μm	14	Spring	SWC
		5 μm	15	Adjusting seat	Aluminum alloy (GFR600)\POM(others)
4	Air guider	High viscosity POM	16	Feedback tube	POM
5	O-ring	NBR	17	Adjusting plug	Brass & Rubber
6	Body of filter-regulator	Aluminum alloy	18	O-ring	NBR
7	Adjusting spool	Brass(GFR600)\POM(others)	19	Spring	SUS304
8	O-ring	NBR	20	Liquid meter cover	SPCC
9	Diaphragm	SUS304 & Rubber	21	Liquid meter seal	VITON
10	Fixation ring cap	Aluminum alloy (GFR600)\POM(others)	22	Liquid meter inside cover	PC



Preparation unit—G Series



GFR Series Filter & regulator

Pressure chart

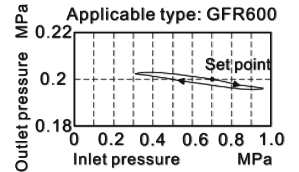
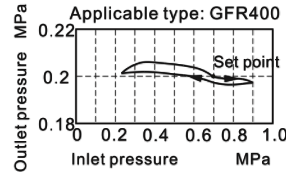
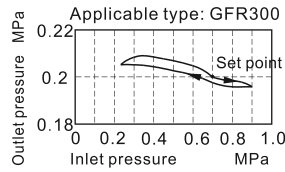
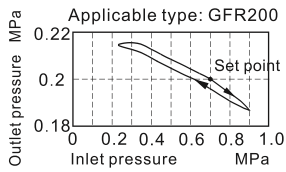

Flow chart

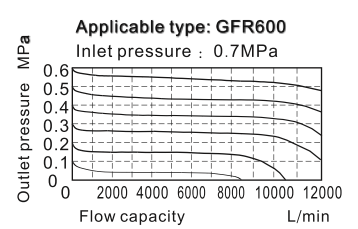
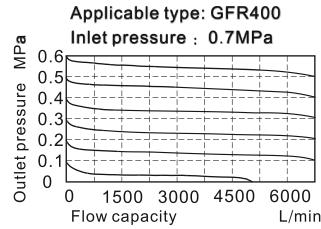
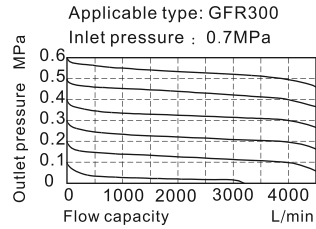
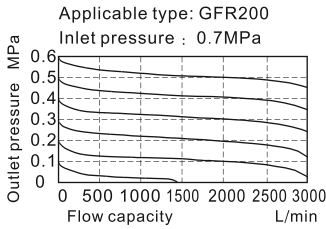

Selection of drain mode

GFR200

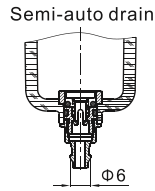
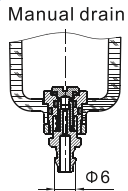

PU tube with an inner diameter of $\Phi 5$ or $\Phi 5.5$ mm is recommended

GFR300\GFR400\GFR600

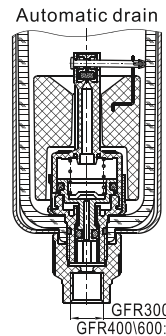
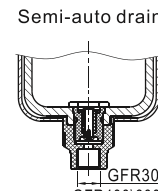
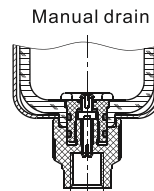

Dimensions

GFR200

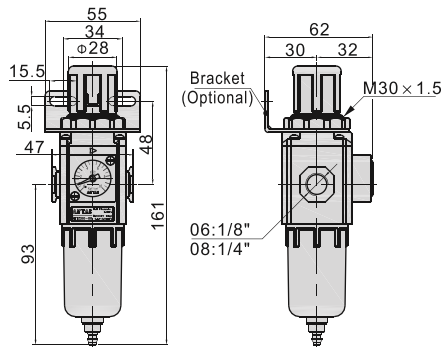

GFR300\GFR400

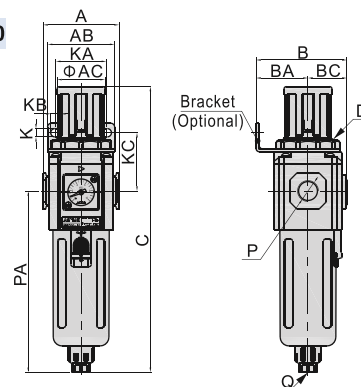

GFR600

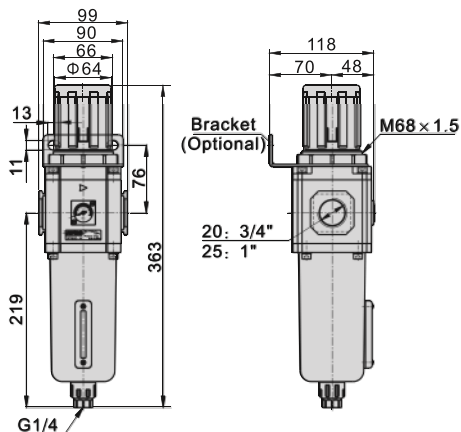

Model\Item	A	AB	AC	B	BA	BC	C	D
GFR300-08	60	53	38	72	41	31	225.5	M40x1.5
GFR300-10	60	53	38	72	41	31	225.5	M40x1.5
GFR300-15	60	53	38	72	41	31	225.5	M40x1.5
GFR400-10	80	72	52	90	50	40	270.5	M55x2.0
GFR400-15	80	72	52	90	50	40	270.5	M55x2.0

Model\Item	K	KA	KB	KC	P	PA	Q
GFR300-08	6.5	40	8	46	1/4"	143	G1/8
GFR300-10	6.5	40	8	46	3/8"	143	G1/8
GFR300-15	6.5	40	8	46	1/2"	143	G1/8
GFR400-10	8.5	52	11	53	3/8"	166.5	G1/4
GFR400-15	8.5	52	11	53	1/2"	166.5	G1/4

Regulating way

The use of GFR series regulators is the same as the SDR series, please refer to Page 196 for details.

