

Preparation unit—G Series



GF Series Filter



Symbol



Product feature

1. Unique diversion structure spins the air flowing through to effectively separate the liquid from the air and reliably filter the solid grain.
2. It has low pressure loss, high efficiency in separating water and large drain bowl capacity.
3. Filtering grade includes 5 μm and 40 μm (Optional).
4. Three drain types are available: manual drain, semi-auto drain and automatic drain.
5. The bracket can be selected for installation.

Specification

Model	GF200-06	GF200-08	GF300-08	GF300-10	GF300-15	GF400-10	GF400-15	GF600-20	GF600-25
Fluid	Air								
Port size [Note1]	1/8"	1/4"	1/4"	3/8"	1/2"	3/8"	1/2"	3/4"	1"
Filtering grade	40 μm or 5 μm								
Pressure range	Semi-auto and automatic drain: 0.15~1.0MPa(20~145psi); Manual drain: 0~0.9MPa(0~145psi)								
Proof pressure	1.5MPa(215psi)								
Temperature range	-5~70°C(Unfreeze)								
Capacity of drain bowl	10CC		40CC			80CC		230CC	
Weight	135g		360g			680g		1440g	

[Note1] PT thread, G thread and NPT thread are available.

Ordering code

GF200 08 M □ W G

① ② ③ ④ ⑤ ⑥

① Model	② Port size	③ Drain type	④ Accessories	⑤ Filtering grade	⑥ Thread type
GF200: G200 Series Filter	06: 1/8" 08: 1/4"	Blank: Semi-auto drain M: Manual drain	Blank: BracketJ: No bracket(standard configuration)	Blank: 40 μm W: 5 μm	Blank: PT G: G T: NPT
GF300: G300 Series Filter	08: 1/4" 10: 3/8" 15: 1/2"	Blank: Semi-auto drain M: Manual drain A: Automatic drain			
GF400: G400 Series Filter	10: 3/8" 15: 1/2"				
GF600: G600 Series Filter	20: 3/4" 25: 1"				

Innerstructure

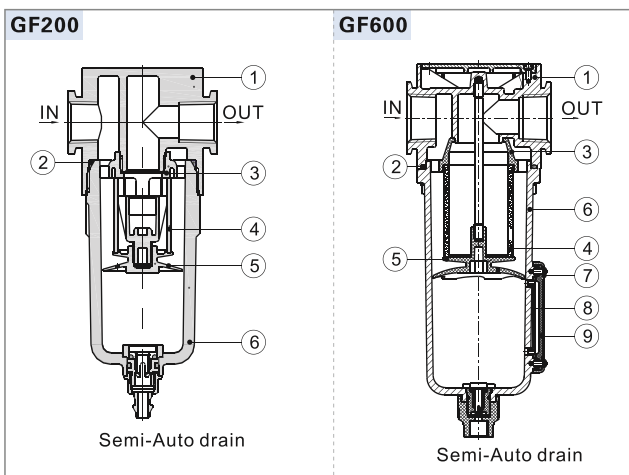

No.	Item	Material
1	Body	Aluminum alloy
2	O-ring	NBR
3	Air guide	High viscosity POM
4	Filter core	Makrolon fiber(5 μm) Agglomerated by bronze grain(40 μm or GF600)
5	Umbrella baffle	High viscosity POM
6	Drain bowl	Aluminum alloy(GF600)\PC(Others)
7	Liquid meter cover	SPCC
8	Liquid meter seal	VITON
9	Liquid meter inside cover	PC



Preparation unit — G Series



GF Series Filter

Flow chart

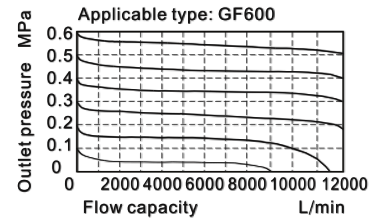
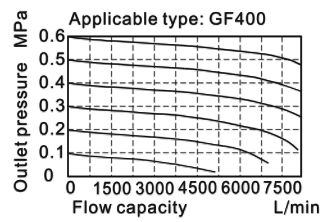
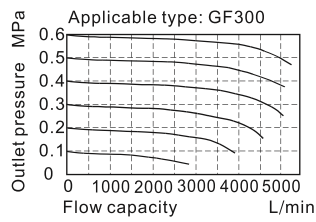
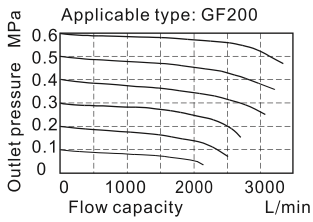

Dimensions

GF200

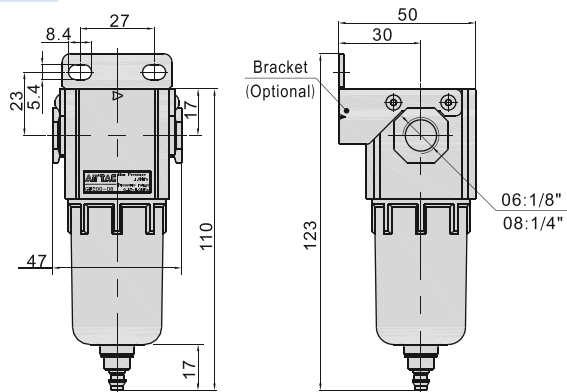

GF300\GF400

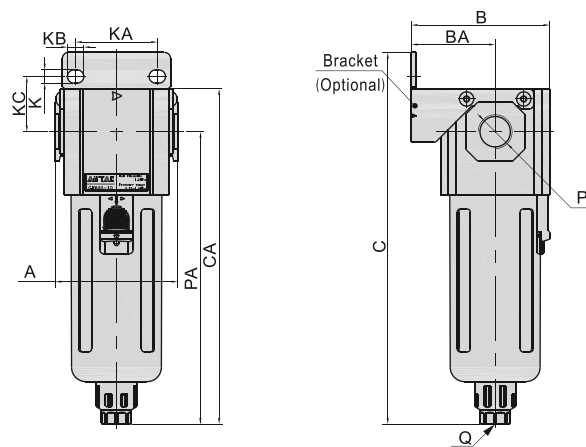

GF600

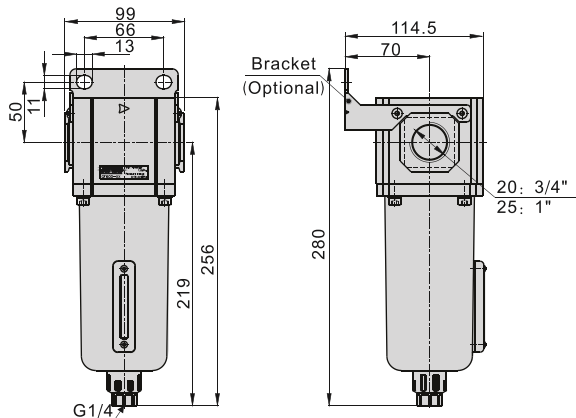

Model\Item	A	B	BA	C	CA	K	KA	KB	KC	P	PA	Q
GF300-08	60	67.5	41	182	164	6.5	40	8	27	1/4"	143	G1/8
GF300-10	60	67.5	41	182	164	6.5	40	8	27	3/8"	143	G1/8
GF300-15	60	67.5	41	182	164	6.5	40	8	27	1/2"	143	G1/8
GF400-10	80	85.5	50	208	191.5	8.5	55	11	33.5	3/8"	166.5	G1/4
GF400-15	80	85.5	50	208	191.5	8.5	55	11	33.5	1/2"	166.5	G1/4

Selection of drain mode

GF series drain mode is the same as the GFR series, please refer to the specific P160.

