



Twist clamp cylinder—ACK Series

Compendium of ACK Series

Single and double side clamping fingers are available

Single push plate (ACK)



Double push plate (ACKD)



Turn left and turn right are available

Push and turn left(L)

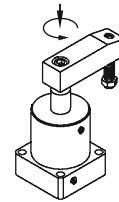

Push and turn right(R)

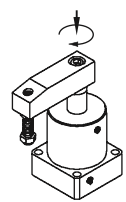

Longer life

The material of piston rod is made from special alloy steel, which has longer life after heat treatment.

Five kinds of bore size

Bore size: 25、32、40、50、63



Theoretical clamping force

Unit: Newton(N)

Bore size (mm)	Rod size (mm)	Operating pressure(MPa)						
		0.1	0.2	0.3	0.4	0.5	0.6	0.7
25	14	-	67.4	101.1	134.8	168.5	202.2	235.9
32	16	60.3	120.6	181.0	241.3	301.6	361.9	422.2
40	16	105.6	211.1	316.7	422.2	527.8	633.3	738.9
50	20	164.9	329.9	494.8	659.7	824.7	989.6	1154.5
63	20	280.3	560.6	840.9	1121.2	1401.5	1681.9	1962.2

Installation and application



1. Clamping operation must be carried out within the clamping stroke and can not be performed within the swivel stroke.
2. Clamping plane must be vertical to the cylinder axes. After the components are clamped, don't move the components.
3. Before the cylinder is connected to pipeline, sundries in the pipe must be eliminated to prevent impurities entering the cylinder.
4. The medium used by cylinder shall be filtered to 40 μm or below.
5. If the cylinder is dismantled and stored for a long time, please conduct anti-rust treatment to the surface. Anti-dust cap shall be added in inlet and outlet ports.

The end of piston shall be coated with anti-rust oil.

Rocking shaft initial point adjustment

According to the actual need, loosening screw, may adjust the rocking shaft initial point.

Note: When assemble or disassemble the rocker by spanner and allen wrench; don't hold the body to assemble or disassemble rocker, it may damage the cylinder.

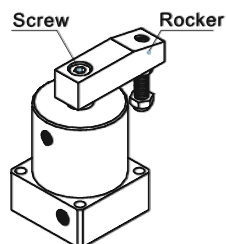

How to select the fitting for body's port

When ACK series with 180° rotation or ACKD is selected, miniature air fittings should be used to minimise obstruction.

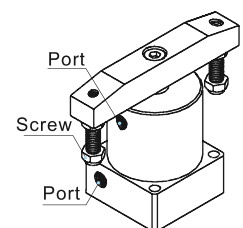

Twist clamp cylinder



ACK Series



Specification

Bore size(mm)	25	32	40	50	63
Acting type	Double acting				
Fluid	Air(to be filtered by 40 μm filter element)				
Operating pressure	0.15~1.0MPa(22~145psi)				
Proof pressure	1.5MPa(215psi)				
Temperature °C	-20~70				
Speed range mm/s	50~200				
Stroke tolerance	+1.0 0				
Rotary angle tolerance	± 1.5°				
Cushion type [Note1]	No cushion				
Port size [Note2]	M5×0.8				1/8"

[Note1] If there is no buffering device, exhaust throttle shall be added to achieve buffering effect.

[Note2] PT thread, G thread and NPT thread are available.

Symbol

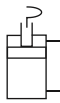

Product feature

1. The material of seals guarantees the reliable performance of the cylinder that is used under various conditions.
2. Three-slot guide structure leads to high guide precision.
3. There are single and double side clamping fingers can be selected (90°).
4. Levorotatory and dextrorotary are available; 90° and 180°.
5. The material of piston rod is made from special alloy steel, which has longer life after heat treatment.

Stroke

Bore size(mm)	Stroke type	90°	180°	Total stroke (90° /180°)
25	Rotation stroke	14	20	26
	Clamping stroke	12	6	26
32	Rotation stroke	15	21	27
	Clamping stroke	12	6	27
40	Rotation stroke	15	21	29
	Clamping stroke	14	8	29
50	Rotation stroke	15	21	29
	Clamping stroke	14	8	29
63	Rotation stroke	15	21	29
	Clamping stroke	14	8	29

Ordering code

ACK L 25 × 90 □

① ② ③ ④ ⑤

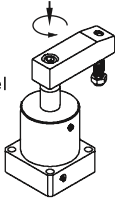
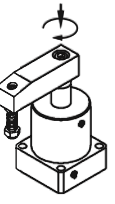
① Model	② Rotary direction	③ Bore size	④ Rotary angle	⑤ Thread type[Note1]
ACK: Twist clamp cylinder(Double acting type) ACKD: Twist clamp cylinder (Double push plate type, only for 90°)	<p>L: Push and turn left</p> <p>When the piston of cylinder moves downward, the swivel arms moves anticlockwise, this is called levorotatory.</p>  <p>R: Push and turn right</p> <p>When the piston of cylinder moves downward, the swivel arms moves clockwise, this is called dextrorotary.</p> 	25 32 40 50 63	90: 90° 180: 180°	Blank: PT G: G T: NPT

[Note1] When the thread is standard, the code is blank.



Twist clamp cylinder



ACK Series

Inner structure and material of major parts

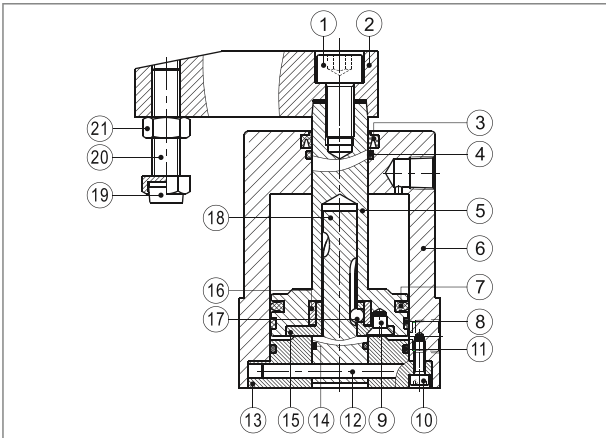

NO.	Item	Material	NO.	Item	Material
1	Screw	Carbon steel	12	Fixed pin	S45C
2	Rocker	Carbon steel	13	Back cover	Aluminum alloy
3	Rod packing	NBR	14	O-ring	NBR
4	O-ring	NBR	15	Push block	SCr440
5	Piston rod	S45C	16	Bushing	SCr440
6	Body	Aluminum alloy	17	Steel ball	Carbon steel
7	Piston seal	NBR	18	Rotary axis	SCr440
8	Wear ring	Wear resistant material	19	Bumper	PTFE
9	Screw	Carbon steel	20	Screw	Carbon steel
10	Screw	Carbon steel	21	Nut	Carbon steel
11	O-ring	NBR			

Dimensions

ACK

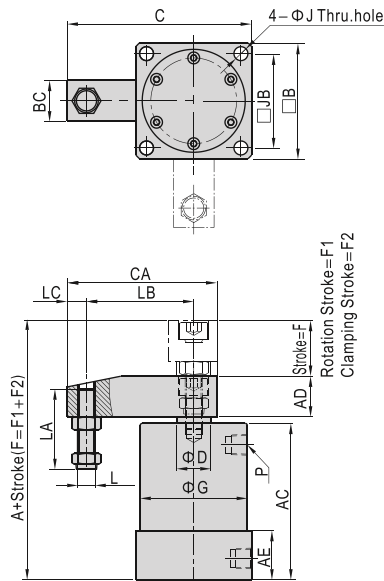

ACKD

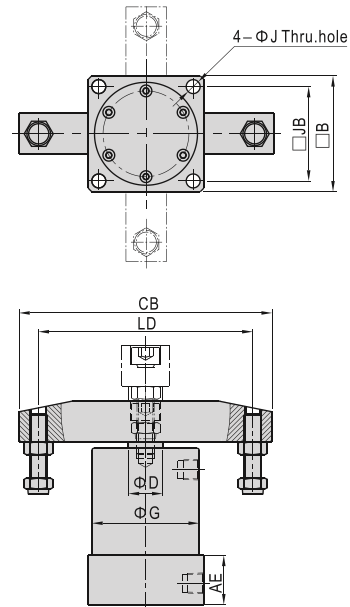

Bore size\Item	A	AC	AD	AE	B	BC	C	CA	CB	D	F(90° /180°)	F1(90°)	F1(180°)	F2(90°)	F2(180°)	G	J	JB	L	LA	LB	LC	LD	P
25	85	65	16	23	40	16	58	48	76	14	26	14	20	12	6	35	4.5	30	M6×1.0	29.5	30	8	60	M5×0.8
32	95	73	19	23	54	19	86	70	118	16	26	14	20	12	6	50	6.5	44	M8×1.25	37.5	50	9	100	1/8"
40	97	74	19	26	58	19	88	70	118	16	27	15	21	12	6	55	6.5	48	M8×1.25	37.5	50	9	100	1/8"
50	109.5	80	25.5	26	68	25.5	114	93	160	20	29	15	21	14	8	60	8.5	55	M10×1.5	45	70	10	140	1/8"
63	115.5	86	25.5	30	82	25.5	121	93	160	20	29	15	21	14	8	70	8.5	64	M10×1.5	45	70	10	140	1/8"



Twist clamp cylinder



ACK Series

How to select product

- When arms are to be made separately, their length and weight should be within the following range.
- Allowable bending moment:
Use the arm length and operating pressure within graph(1) for allowable bending moment loaded piston rod.

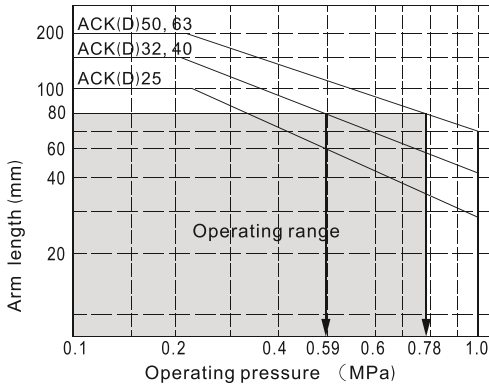

Example: When arm length is 80mm, pressure should be less than
ACK32/40:0.59MPa ACK50/63:0.78MPa

- Moment of inertia:
When the arm is long and heavy, damage of internal parts may be caused due to inertia. Use the inertia moment and cylinder speed within graph(2) based on arm requirements.

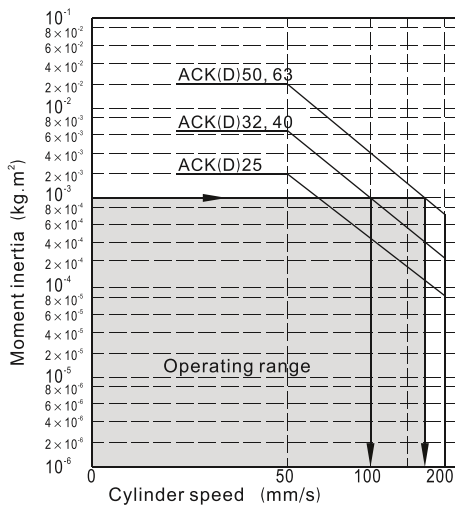

Example: When arm's moment of inertia is $10^{-3} \text{Kg}\cdot\text{m}^2$, cylinder speed should be less than
ACK32/40:100mm/s
ACK50/63:170mm/s

Note) The average speed of piston=the highest speed of piston/1.6

- Moment of inertia of cylinder's arm when rotating based on its rotary axis, shown in graph(3).

Model	Moment of inertia(Kg·m ²)
ACK25 with single arm	2.006×10^{-5}
ACK25 with double arms	7.651×10^{-5}
ACK32\40 with single arm	1.271×10^{-4}
ACK32\40 with double arms	4.148×10^{-4}
ACK50\63 with single arm	9.614×10^{-4}
ACK50\63 with double arms	1.888×10^{-3}

- Calculation reference:
5.1) Moment of inertia of arm (I₁) : Refer to the graph(3) after the cylinder bore diameter is determined.
5.2) Moment of inertia of jig (I₂) : According to shape of the jig and the next item 6 "Calculation for moment of inertia", pick out a proper formula for calculation. The jig shown on the right graph is a cylinder, its formula of moment of inertia is:
 $I_2 = (m_2 * D * D) / 8 + m_2 * L * L$
When ACK32 is selected: L=0.05m (arm length);
If D=0.04m m₂=0.4kg

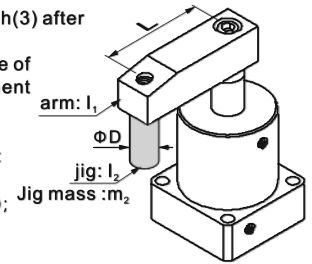

From graph(3): I₁= $1.271 \times 10^{-4} \text{(Kg}\cdot\text{m}^2)$

By Calculation : $I_2 = (m_2 * D * D) / 8 + m_2 * L * L = (0.4 * 0.04 * 0.04) / 8 + 0.4 * 0.05 * 0.05 = 10.8 \times 10^{-4} \text{(Kg}\cdot\text{m}^2)$

Total value: $I = I_1 + I_2 = 12.071 \times 10^{-4} = 1.2071 \times 10^{-3} \text{(Kg}\cdot\text{m}^2)$

According to graph(2), the highest speed of the cylinder should be less than 95 mm/s; According to graph(1), it can be used under a pressure of 0.9MPa. The average speed of piston=the highest speed of piston/1.6=59 mm/s.

- Calculation for moment of inertia

Diagram	Calculation formula of moment of inertia
1. Thin bar Position of rotary axis: Vertical to the bar and through the end	$I = \frac{m_1 a_1^2 + m_2 a_2^2}{3}$
2. Thin bar Position of rotary axis: Vertical to the bar and through the center of gravity	$I = \frac{m a^2}{12}$
3. Load at the end of lever arm	$I = m_1 \times \frac{a_1^2}{3} + m_2 \times a_2^2 + k$ $k = m_2 \times \frac{2r^2}{5}$
4. Thin rectangular plate (Rectangular parallelepiped) Position of rotary axis: Parallel to side b and through the center of gravity	$I = \frac{m a^2}{12}$
5. Thin rectangular plate (Rectangular parallelepiped) Position of rotary axis: Vertical to the plate and through the end	$I = m_1 \times \frac{4a_1^2 + b^2}{12} + m_2 \times \frac{4a_2^2 + b^2}{12}$
6. Thin rectangular plate (Rectangular parallelepiped) Position of rotary axis: Through the center of gravity and vertical to the plate (Same as also thick rectangular plate)	$I = \frac{m a^2 + m b^2}{12}$

