

Compact cylinder—ACE Series

In accordance with ISO21287 standard

Compendium of ACE Series

In accordance with ISO21287 standard
In accordance with ISO21287 standard, the mounting size is vogue.

Magnetic switch slots around the cylinder body
There are magnetic switch slots around the cylinder body convenient to install inducting switch.

Two kinds of rod type

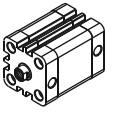

Female thread

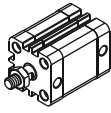

Male thread

Multi-mounting accessories

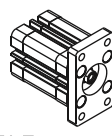

FA Type

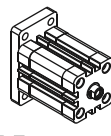

FB Type

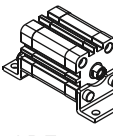

LB Type

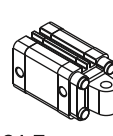

CA Type

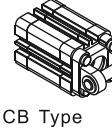

CB Type

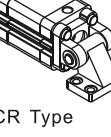

CR Type

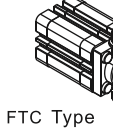



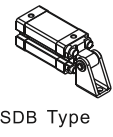



FTC Type



SDB Type

Multi-type cylinder

ACE: Compact cylinder (Double acting)	
ASE: Compact cylinder (Single acting-push)	
ATE: Compact cylinder (Single acting-pull)	
ACED: Compact cylinder (Double rod)	
ACEJ: Compact cylinder (Adjustable stroke)	
TACE: Compact cylinder (Double acting non-rotating with yoke)	
TACED: Compact cylinder (Double rod non-rotating with yoke)	

Compact structure
Compact structure can effectively save fifty percent installation space with ISO15552 standard cylinder.

Eleven bore size are available
Bore size: 12、16、20、25、32、40、50、63、80、100、125

Criteria for selection: Cylinder thrust

Bore size	Rod size	Acting type	Pressure area(mm ²)	Operating pressure(MPa)								Bore size	Rod size	Acting type	Pressure area(mm ²)	Operating pressure(MPa)							
				0.1	0.2	0.3	0.4	0.5	0.6	0.7	0.1					0.2	0.3	0.4	0.5	0.6	0.7		
12	6	Single Push side	113.1	-	6.1	17.4	28.7	40.0	51.4	62.7	40	12	Single Push side	1256.6	54.2	179.8	305.5	431.2	556.8	682.5	808.1		
		Single Pull side	84.8	-	0.5	8.9	17.4	25.9	34.4	42.9			Single Pull side	1143.5	42.9	157.2	271.6	385.9	500.3	614.6	729.0		
		Double Push side	113.1	11.3	22.6	33.9	45.2	56.5	67.9	79.2			Double Push side	1256.6	125.7	251.3	377.0	502.7	628.3	754.0	879.6		
		Double Pull side	84.8	8.5	17.0	25.4	33.9	42.4	50.9	59.4			Double Pull side	1143.5	114.4	228.7	343.1	457.4	571.8	686.1	800.5		
16	8	Single Push side	201.1	-	18.1	38.2	58.3	78.4	98.5	118.6	50	16	Single Push side	1963.5	90.1	286.5	482.8	679.2	875.5	1071.9	1268.2		
		Single Pull side	150.8	-	8.1	23.1	38.2	53.3	68.4	83.5			Single Pull side	1762.4	70.0	246.3	422.5	598.8	775.0	951.3	1127.5		
		Double Push side	201.1	20.1	40.2	60.3	80.4	100.5	120.6	140.7			Double Push side	1963.5	196.3	392.7	589.0	785.4	981.7	1178.1	1374.4		
		Double Pull side	150.8	15.1	30.2	45.2	60.3	75.4	90.5	105.6			Double Pull side	1762.4	176.2	352.5	528.7	705.0	881.2	1057.5	1233.7		
20	10	Single Push side	314.2	-	33.1	64.5	96.0	127.4	158.8	190.2	63	16	Single Push side	3117.2	173.6	485.3	797.1	1108.8	1420.5	1732.2	2044.0		
		Single Pull side	235.6	-	17.4	41.0	64.5	88.1	111.7	135.2			Single Pull side	2916.2	153.5	445.1	736.8	1028.4	1320.0	1611.6	1903.2		
		Double Push side	314.2	31.4	62.8	94.2	125.7	157.1	188.5	219.9			Double Push side	3117.2	311.7	623.4	935.2	1246.9	1558.6	1870.3	2182.1		
		Double Pull side	235.6	23.6	47.1	70.7	94.2	117.8	141.4	164.9			Double Pull side	2916.2	291.6	583.2	874.9	1166.5	1458.1	1749.7	2041.3		
25	10	Single Push side	490.9	13.8	62.9	112.0	161.0	210.1	259.2	308.3	80	20	Single Push side	5026.5	305.6	808.2	1310.9	1813.5	2316.2	2818.8	3321.5		
		Single Pull side	412.3	5.9	47.2	88.4	129.6	170.9	212.1	253.3			Single Pull side	4712.4	274.1	745.4	1216.6	1687.9	2159.1	2630.3	3101.6		
		Double Push side	490.9	49.1	98.2	147.3	196.3	245.4	294.5	343.6			Double Push side	5026.5	502.7	1005.3	1508.0	2010.6	2513.3	3015.9	3518.6		
		Double Pull side	412.3	41.2	82.5	123.7	164.9	206.2	247.4	288.6			Double Pull side	4712.4	471.2	942.5	1413.7	1885.0	2356.2	2827.4	3298.7		
32	12	Single Push side	804.2	30.8	111.2	191.7	272.1	352.5	432.9	513.4	100	20	Single Push side	7854.0	499.1	1284.5	2069.9	2855.3	3640.7	4426.1	5211.5		
		Single Pull side	691.2	19.5	88.6	157.7	226.9	296.0	365.1	434.2			Single Pull side	7539.8	467.7	1221.7	1975.7	2729.6	3483.6	4237.6	4991.6		
		Double Push side	804.2	80.4	160.8	241.3	321.7	402.1	482.5	563.0			Double Push side	7854.0	785.4	1570.8	2356.2	3141.6	3927.0	4712.4	5497.8		
		Double Pull side	691.2	69.1	138.2	270.3	276.5	345.6	414.7	483.8			Double Pull side	7539.8	754.0	1508.0	2262.0	3015.9	3769.9	4523.9	5277.9		
125	25	Double Push side	12271.8	1227.2	2454.4	3681.5	4908.7	6135.9	7363.1	8590.3	125	25	Double Push side	11780.9	1178.1	2356.2	3534.3	4712.4	5890.5	7086.5	8246.6		
		Double Pull side	11780.9	1178.1	2356.2	3534.3	4712.4	5890.5	7086.5	8246.6			Double Pull side	11780.9	1178.1	2356.2	3534.3	4712.4	5890.5	7086.5	8246.6		

Installation and application

1. When load changes in the work, the cylinder with abundant output capacity shall be selected.
2. Relative cylinder with high temperature resistance or corrosion resistance shall be chosen under the condition of high temperature or corrosion.
3. Necessary protection measure shall be taken in the environment with higher humidity, much dust or water drops, oil dust and welding dregs.
4. Dirty substances in the pipe must be eliminated before cylinder is connected with pipeline to prevent the entrance of particles into the cylinder.
5. The medium used by cylinder shall be filtered to 40 μm or below.
6. As both of the front cover and piston of the cylinder are short, typically too large stroke can not be selected.
7. Anti-freezing measure shall be adopted under low temperature environment to prevent moisture freezing.
8. The cylinder shall avoid the influence of side load in operation to maintain the normal work of cylinder and extend the service life.
9. If the cylinder is dismantled and stored for a long time, please conduct anti-rust treatment to the surface. Anti-dust caps shall be added in air inlet and outlet ports. The front and back cover can not be dismantled, which shall be especially noticed.

Compact cylinder



ACE Series



Symbol

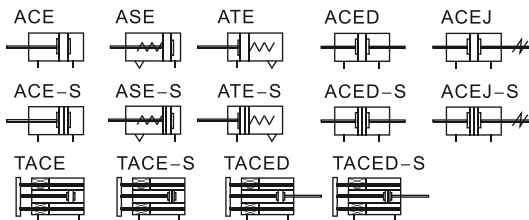

Product feature

- In accordance with ISO21287 standard, the mounting size is vogue.
- The cylinder body connects with the threads of the front and back cover, forming high strength and convenient maintenance.
- The internal diameter of the body is treated with rolling followed by the treatment of hard anodizing, forming an excellent abrasion resistance and durability.
- The seal of piston adopts heterogeneous two-way seal structure. It has compact dimension and the function of oil reservation.
- Compact structure can effectively save fifty percent installation space with ISO15552 standard cylinder.
- There are magnetic switch slots around the cylinder body, which is convenient to install inducting switch.
- Bumper is available and it can availably absorb excrement energy.
- Installing accessories with various specifications are optional.

Ordering code

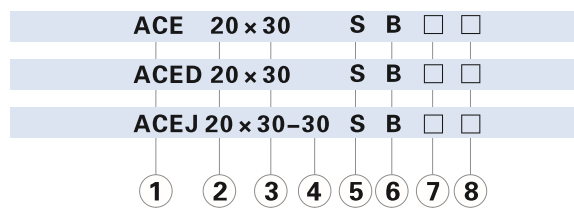

Specification

Bore size(mm)	12	16	20	25	32	40	50	63	80	100	125
Acting type	Double acting										
	Single acting_Push type、Single acting_Pull type										-
Fluid	Air(to be filtered by 40 μ m filter element)										
Operating pressure	Double acting		0.15~1.0MPa(22~145psi)								
	Single acting		0.2~1.0MPa(28~145psi)								
Proof pressure	1.5MPa(215psi)										
Temperature °C	-20~70										
Speed range mm/s	Double acting: 30~500					Single acting: 50~500					
Stroke tolerance	Stroke≤100 + ₀ ⁰					Stroke>100 + ₀ ^{1.5}					
Cushion type	Bumper										
Port size [Note1]	M5×0.8					G1/8			G1/4		

[Note1] PT thread, G thread thread and NPT thread are available.
Add) Refer to P313 for detail of sensor switch.

Stroke

Bore size (mm)	Standard stroke (mm)											Max.stroke																		
Common type	Double acting	12	5	10	15	20	25	30	35	40	45	50	50																	
		16	5	10	15	20	25	30	35	40	45	50	55	60	70	75														
		20	5	10	15	20	25	30	35	40	45	50	55	60	70	75	80	90	100											
		25	5	10	15	20	25	30	35	40	45	50	55	60	70	75	80	90	100	110	120	125	150							
		32 40	5	10	15	20	25	30	35	40	45	50	55	60	70	75	80	90	100	110	120	125	150	160	175	200				
Non-rotating with yoke	Double acting	50 63	5	10	15	20	25	30	35	40	45	50	55	60	70	75	80	90	100	110	120	125	150	160	175	200	225	250	250	
		80 100 125	5	10	15	20	25	30	35	40	45	50	55	60	70	75	80	90	100	110	120	125	150	160	175	200	225	250	275	300
		Single acting	12	5	10	10	10	10	10	10	10	10	10	10	10	10	10	10	10	10	10	10	10	10	10	10	10	10	10	
			16~100	5	10	15	20	25	25	25	25	25	25	25	25	25	25	25	25	25	25	25	25	25	25	25	25	25	25	
			Double acting	12	5	10	15	20	25	30	35	40	45	50	50	50	50	50	50	50	50	50	50	50	50	50	50	50	50	
16	5			10	15	20	25	30	35	40	45	50	55	60	70	75	80	90	100	100	100	100	100	100	100	100	100			
Non-rotating with yoke	Single acting	20 25	5	10	15	20	25	30	35	40	45	50	55	60	70	75	80	90	100	100	100	100	100	100	100	100	100			
		32 40	5	10	15	20	25	30	35	40	45	50	55	60	70	75	80	90	100	100	100	100	100	100	100	100				
		50 63	5	10	15	20	25	30	35	40	45	50	55	60	70	75	80	90	100	100	100	100	100	100	100	100				
		80 100	5	10	15	20	25	30	35	40	45	50	55	60	70	75	80	90	100	100	100	100	100	100	100	100				
		100	5	10	15	20	25	30	35	40	45	50	55	60	70	75	80	90	100	100	100	100	100	100	100	100				

- Note) 1. Please contact the company for other special strokes.
2. The dimensions of non-std stroke cylinder has the same dimensions as the next longer stroke std. stroke cylinder. e.g. 23mm stroke cylinder has the same dimensions of 25 std. stroke cylinder.

① Model	② Bore size	③ Stroke	④ Adjustable Stroke	⑤ Magnet	⑥ Rod type	⑦ Mounting type [Note1]	⑧ Thread type [Note2]
ACE: Compact cylinder (Double acting)	12 16 20 25 32 40 50 63 80 100 125	Refer to stroke table for details	No this code	Blank: Without magnet S: With magnet	Blank: Female thread B: Male thread	Blank: No accessories FA: FA type FB: FB type CA: CA type CB: CB type	CR: CR type FTC: FTC type LB: LB type SDB: SDB type
ASE: Compact cylinder (Single acting-push)	12 16 20 25 32 40 50 63 80 100						
ATE: Compact cylinder (Single acting-pull)					Blank: No accessories FB: FB type	CB: CB type CR: CR type FTC: FTC type	
TACE: Compact cylinder (Double acting non-rotating with yoke)							Blank: No accessories FB: FB type
TACED: Compact cylinder (Double rod non-rotating with yoke)					Blank: Female thread B: Male thread	Blank: No accessories FA: FA type FTC: FTC type LB: LB type	
ACED: Compact cylinder (Double rod)	10 20 30 40 50 75 100						
ACEJ: Compact cylinder (Adjustable stroke)	80 100 125						

[Note1] Please refer to page 112~114 for accessory parts; CR must be used with CB, SDB must be used with CA, FTC must be used with TCM2.

[Note2] Standard thread is blank here.



Compact cylinder



ACE Series

Inner structure and material of major parts

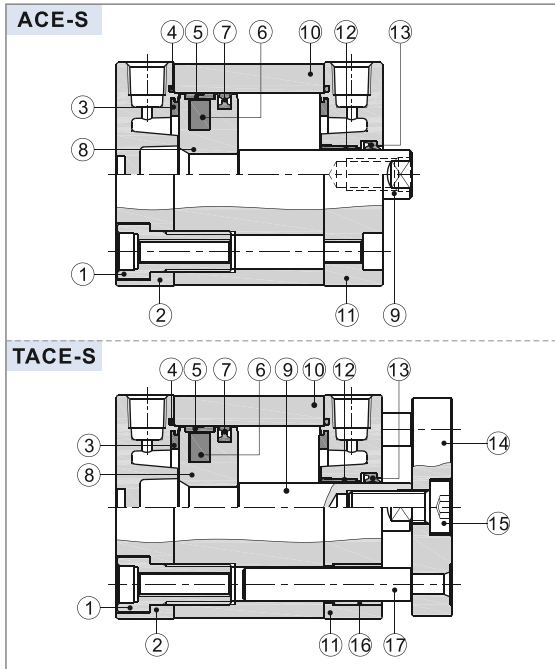

NO.	Item	Material
1	Screw	Carbon steel
2	Back cover	Aluminum alloy
3	Bumper	TPU
4	O-ring	NBR
5	Wear ring	No(Φ12~20)\Wear resistant material(Others)
6	Magnet	Sintered metal(Neodymium-iron-boron)(Φ12~20)\Plastic(Others)
7	Piston seal	NBR
8	Piston	Aluminum alloy
9	Piston rod	S45C
10	Body	Aluminum alloy
11	Front cover	Aluminum alloy
12	Bushing	No(Φ12~25)\Wear resistant material(Others)
13	Front cover packing	NBR
14	Panel	Aluminum alloy
15	Screw	Carbon steel
16	Bushing	Wear resistant material
17	Guide rod	Stainless steel(Φ12~40)\S45C(Others)

Dimensions

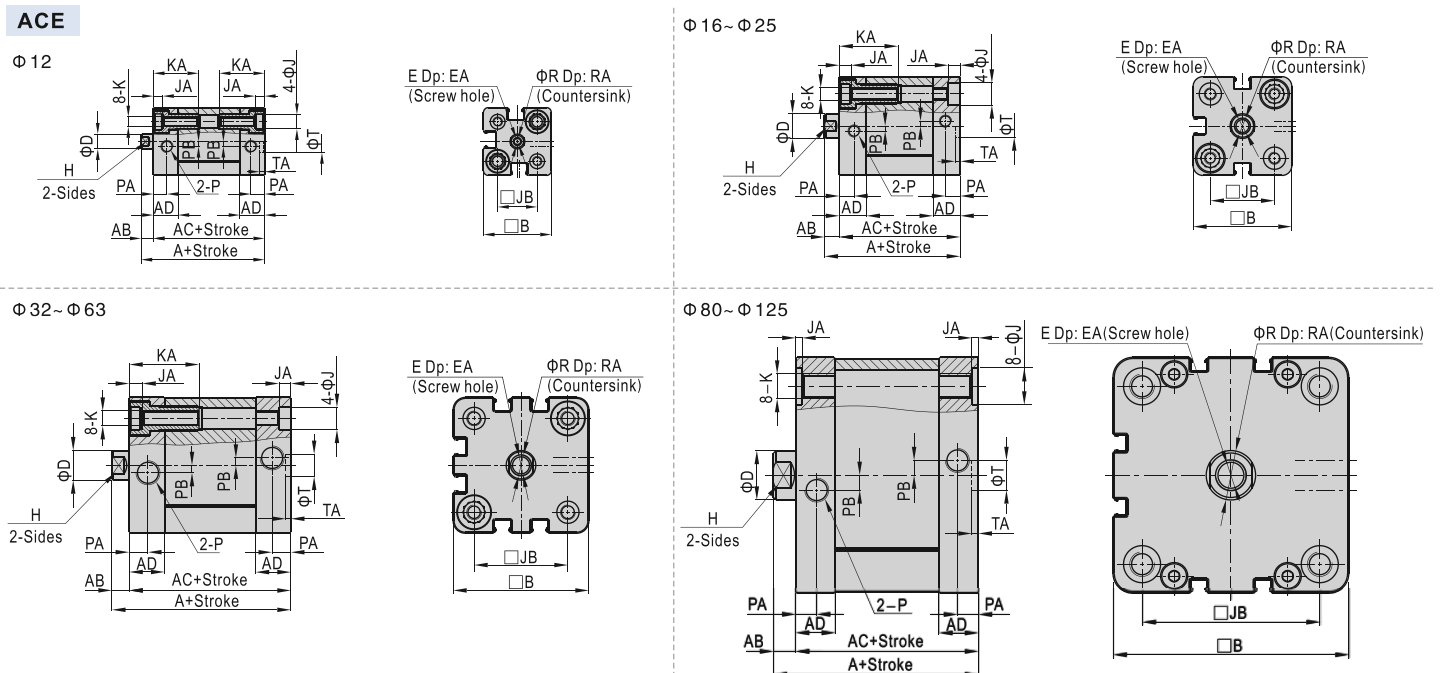

Bore size\Item	A	AB	AC	AD	B	D	E	EA	H	J	JA	JB	K	KA	P	PA	PB	R	RA	T	TA
12	40	5	35	10	27.5	6	M3×0.5	8	5	6	3.5	16	M4×0.7	18.5	M5×0.8	5.5	2	3.5	1.5	9	2.1
16	40	5	35	10	30	8	M4×0.7	10	7	6	3.5	18	M4×0.7	18.5	M5×0.8	5.5	2	4.5	1.5	9	2.1
20	43	6	37	10.5	35.5	10	M6×1.0	14	9	9	4.5	22	M5×0.8	23.5	M5×0.8	6	2	6.5	2.5	9	2.1
25	45	6	39	11	40	10	M6×1.0	14	9	9	4.5	26	M5×0.8	23.5	M5×0.8	6	2	6.5	2.5	9	2.1
32	51	7	44	14	49.5	12	M8×1.25	16	10	9	4.5	32.5	M6×1.0	28.5	G1/8	7.5	3	8.5	3.5	9	2.1
40	52.5	7	45.5	14.5	55	12	M8×1.25	16	10	9	4.5	38	M6×1.0	28.5	G1/8	7.5	3	8.5	3.5	9	2.1
50	53.5	8	45.5	14.5	65.5	16	M10×1.5	20	13	11	4.5	46.5	M8×1.25	30.5	G1/8	7.5	3	10.5	4.5	12	2.6
63	57	8	49	15	75.5	16	M10×1.5	20	13	11	4.5	56.5	M8×1.25	30.5	G1/8	7.5	4	10.5	4.5	12	2.6
80	63	9	54	16	95.5	20	M12×1.75	20	17	15	2.5	72	M10×1.5	-	G1/8	8.5	6	12.5	6	12	2.6
100	76	9	67	19	113.5	20	M12×1.75	20	17	15	2.5	89	M10×1.5	-	G1/8	10.5	7	12.5	6	12	2.6
125	92	11	81	20	134.5	25	M16×2.0	25	21	-	-	110	M12×1.75	-	G1/4	10.5	8	16.5	7	12	2.6

Remark: The dimensions of magnet type cylinder are the same as non-magnet type cylinder. Please refer to page 111 for male thread dimensions.



Compact cylinder



ACE Series

ASE

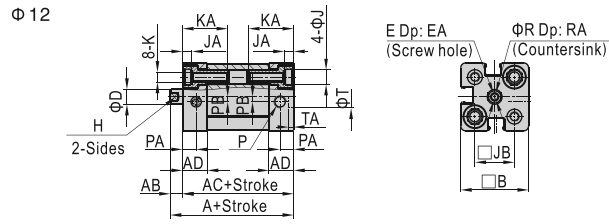

$\Phi 16 \sim \Phi 25$

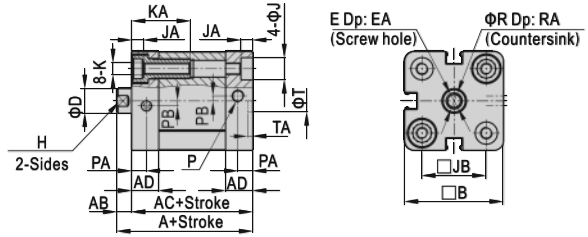

$\Phi 32 \sim \Phi 63$

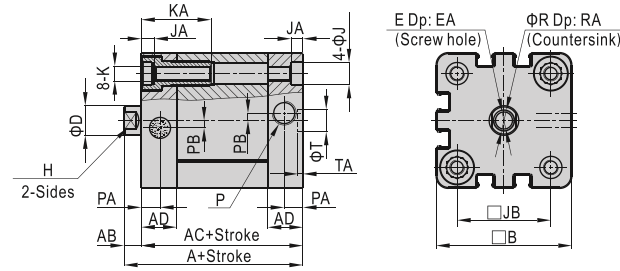

$\Phi 80 / \Phi 100$

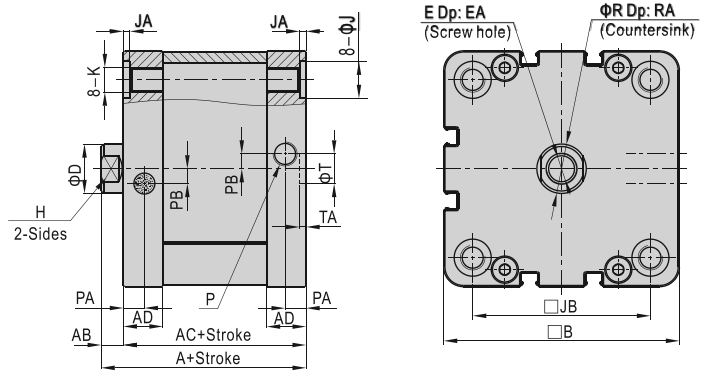

ATE

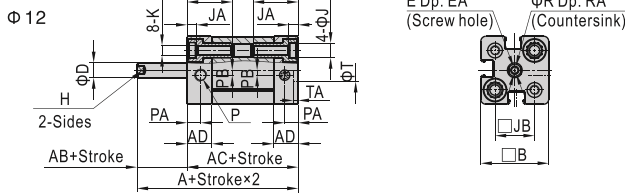

$\Phi 16 \sim \Phi 25$

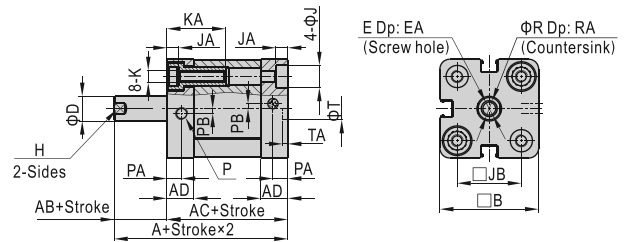

$\Phi 32 \sim \Phi 63$

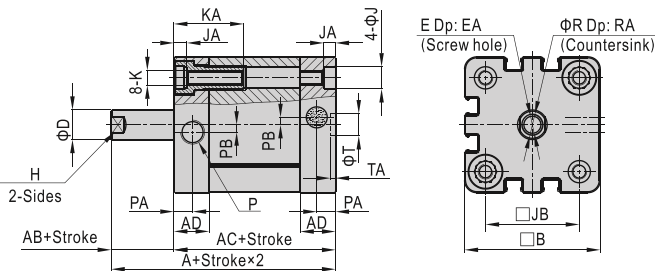

$\Phi 80 / \Phi 100$

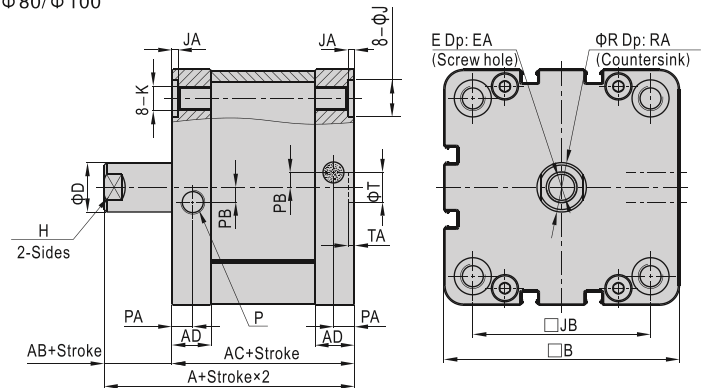

Bore size/Item	A	AB	AC	AD	B	D	E	EA	H	J	JA	JB	K	KA	P	PA	PB	R	RA	T	TA
12	40	5	35	10	27.5	6	M3×0.5	8	5	6	3.5	16	M4×0.7	18.5	M5×0.8	5.5	2	3.5	1.5	9	2.1
16	40	5	35	10	30	8	M4×0.7	10	7	6	3.5	18	M4×0.7	18.5	M5×0.8	5.5	2	4.5	1.5	9	2.1
20	43	6	37	10.5	35.5	10	M6×1.0	14	9	9	4.5	22	M5×0.8	23.5	M5×0.8	6	2	6.5	2.5	9	2.1
25	45	6	39	11	40	10	M6×1.0	14	9	9	4.5	26	M5×0.8	23.5	M5×0.8	6	2	6.5	2.5	9	2.1
32	51	7	44	14	49.5	12	M8×1.25	16	10	9	4.5	32.5	M6×1.0	28.5	G1/8	7.5	3	8.5	3.5	9	2.1
40	52.5	7	45.5	14.5	55	12	M8×1.25	16	10	9	4.5	38	M6×1.0	28.5	G1/8	7.5	3	8.5	3.5	9	2.1
50	53.5	8	45.5	14.5	65.5	12	M10×1.5	20	13	11	4.5	46.5	M8×1.25	30.5	G1/8	7.5	3	10.5	4.5	12	2.6
63	57	8	49	15	75.5	16	M10×1.5	20	13	11	4.5	56.5	M8×1.25	30.5	G1/8	7.5	4	10.5	4.5	12	2.6
80	63	9	54	16	95.5	20	M12×1.75	20	17	15	2.5	72	M10×1.5	-	G1/8	8.5	6	12.5	6	12	2.6
100	76	9	67	19	113.5	20	M12×1.75	20	17	15	2.5	89	M10×1.5	-	G1/8	10.5	7	12.5	6	12	2.6

Remark: The dimensions of magnet type cylinder are the same as non-magnet type cylinder. Please refer to page 111 for male thread dimensions.



Compact cylinder



ACE Series

ACED

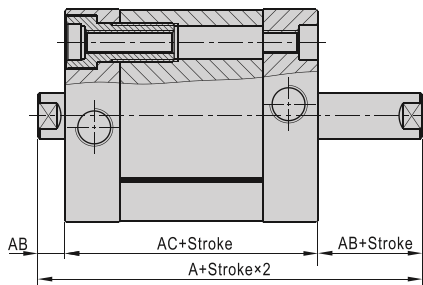

ACEJ

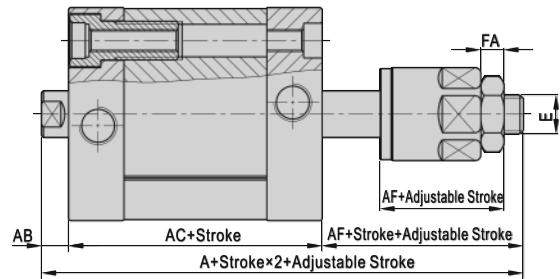

Bore size\Item	A(ACED)	A(ACEJ)	AB	AC	AF	FA	E
12	45	57	5	35	17	4	M5×0.8
16	45	61	5	35	21	5	M6×1.0
20	49	68	6	37	25	6	M8×1.25
25	51	70	6	39	25	6	M8×1.25
32	58	78	7	44	27	6	M10×1.25
40	59.5	79.5	7	45.5	27	6	M10×1.25
50	61.5	81.5	8	45.5	28	7	M12×1.25
63	65	85	8	49	28	7	M12×1.25
80	72	92	9	54	29	8	M16×1.5
100	85	105	9	67	29	8	M16×1.5
125	103	127.5	11	81	35.5	10	M20×1.5

Remark:

1. The unmarked dimension is the same as ACE standard type
2. The dimensions of magnet type cylinder are the same as non-magnet type cylinder.

TACE

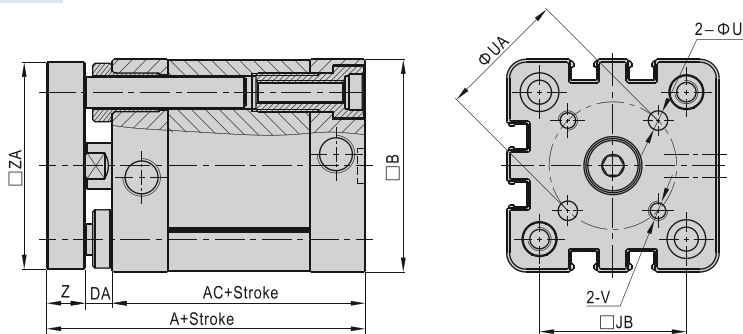

Male thread

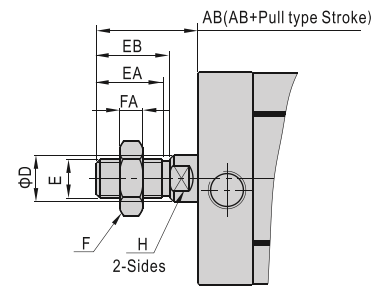

Bore size\Item	AB	D	E	EA	EB	F	FA	H
12	15	6	M5×0.8	9	10	8	4	5
16	17	8	M6×1.0	11	12	10	5	7
20	22	10	M8×1.25	15	16	12	6	9
25	22	10	M8×1.25	15	16	12	6	9
32	26	12	M10×1.25	17	19	17	6	10
40	26	12	M10×1.25	17	19	17	6	10
50	30	16	M12×1.25	20	22	17	7	13
63	30	16	M12×1.25	20	22	17	7	13
80	37	20	M16×1.5	26	28	23	8	17
100	37	20	M16×1.5	26	28	23	8	17
125	51	25	M20×1.5	38	40	26	10	21

TACED

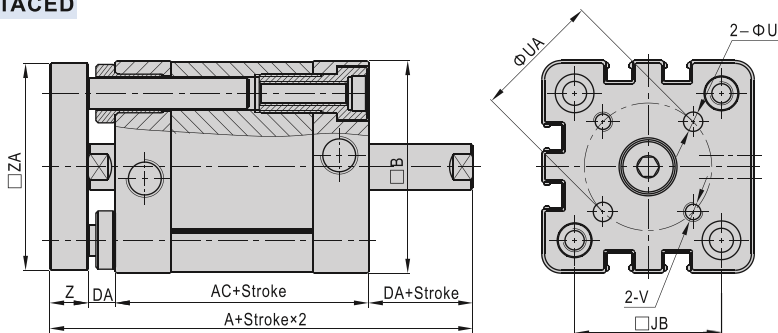

Bore size\Item	A(TACE)	A(TACED)	AC	B	DA	JB	U	UA	V	Z	ZA
12	46	51	35	27.5	5	16	3	12	M3×0.5	6	26.5
16	46	51	35	30	5	18	3	14	M3×0.5	6	29
20	51	57	37	35.5	6	22	4	17	M4×0.7	8	34.5
25	53	59	39	40	6	26	5	22	M5×0.8	8	39
32	61	68	44	49.5	7	32.5	5	28	M5×0.8	10	48
40	62.5	69.5	45.5	55	7	38	5	33	M5×0.8	10	53.5
50	65.5	73.5	45.5	65.5	8	46.5	6	42	M6×1.0	12	64
63	69	77	49	75.5	8	56.5	6	50	M6×1.0	12	74
80	77	86	54	95.5	9	72	8	65	M8×1.25	14	94
100	90	99	67	113.5	9	89	10	80	M10×1.5	14	112

Remark:

1. The unmarked dimension is the same as ACE standard type
2. The dimensions of magnet type cylinder are the same as non-magnet type cylinder.



Compact cylinder



ACE Series—Accessories

List for ordering code of accessories

Accessories Bore size	Mounting accessories									Knuckle				Sensor switch	
	LB	FA/FB	CA	CB	CR	SDB	FTC	TCM2	I	Y	F	U	CS1-E	DS1-E	
12	F-ACE12LB	F-ACE12FA	F-ACE12CA	-	-	F-MI12SDB	-	-	F-ACQ12I	F-ACQ12Y	F-M5X080F	F-M5X080U	CS1-E	DS1-E	
16	F-ACP12LB	F-ACE16FA	F-ACE16CA	-	-	F-MI12SDB	-	-	F-M6X100I	F-M6X100Y	F-M6X100F	F-M6X100U			
20	F-ACP20LB	F-ACE20FA	F-ACE20CA	-	-	F-MI20SDB	-	-	F-M8X125I	F-M8X125Y	F-M8X125F	F-M8X125U			
25	F-ACP25LB	F-ACE25FA	F-ACE25CA	-	-	F-MI20SDB	-	-	F-M10X125I	F-M10X125Y	F-M10X125F	F-M10X125U			
32	F-ACE32LB	F-SI32FA	F-SE32CA	F-SE32CB	F-SI32CR	-	F-SI32FTC	F-SI32TCM2	F-M12X125I	F-M12X125Y	F-M12X125F	F-M12X125U			
40	F-ACE40LB	F-SI40FA	F-SE40CA	F-SE40CB	F-SI40CR	-	F-SI40FTC	F-SI40TCM2	F-M16X150I	F-M16X150Y	F-M16X150F	F-M16X150U			
50	F-ACE50LB	F-SI50FA	F-SE50CA	F-SE50CB	F-SI50CR	-	F-SI50FTC	F-SI50TCM2	F-M20X150I	F-M20X150Y	F-M20X150F	F-M20X150U			
63	F-ACE63LB	F-SI63FA	F-SE63CA	F-SE63CB	F-SI63CR	-	F-SI63FTC	F-SI63TCM2							
80	F-ACE80LB	F-SI80FA	F-SE80CA	F-SE80CB	F-SI80CR	-	F-SI80FTC	F-SI80TCM2							
100	F-ACE100LB	F-SI100FA	F-SE100CA	F-SE100CB	F-SI100CR	-	F-SI100FTC	F-SI125TCM2							
125	-	F-SI125FA	F-SE125CA	F-SE125CB	F-SI125CR	-	F-SI125FTC	F-SI125TCM2							

Accessory selection

Cylinder model\Accessories			Mounting accessories									Knuckle[Note1]				Sensor switch			
			LB	FA	FB	CA	CB	CR	SDB	FTC	TCM2	I	Y	U	F	CS1-E	DS1-E		
ACE	Female thread	Without magnet											×	×	×	×	×	×	
		With magnet	●	●	●	●	●	●	●	●	●	●					●	●	
	Male thread	Without magnet												●	●	●	●	×	×
		With magnet												●	●	●	●	●	●
ASE ATE	Female thread	Without magnet											×	×	×	×	×	×	
		With magnet	●	●	●	●	●	●	●	●	●	●					●	●	
	Male thread	Without magnet												●	●	●	●	×	×
		With magnet												●	●	●	●	●	●
ACED ACEJ	Female thread	Without magnet											×	×	×	×	×	×	
		With magnet	●	●	×	×	×	×	×	●	●						●	●	
	Male thread	Without magnet												●	●	●	●	×	×
		With magnet												●	●	●	●	●	●
TACE	Female thread	Without magnet	×	×	●	●	●	●	●	●	●		×	×	×	×	×	×	
		With magnet												×	×	×	×	●	●
TACED	Female thread	Without magnet	×	×	●	×	×	×	×	×	×		×	×	×	×	×	×	
		With magnet												×	×	×	×	●	●

[Note1] The I knuckle and Y knuckle for bore $\Phi 12$ are adaptable to ACQ cylinders, and other knuckles are common parts. Please refer to P302~305 for knuckle detail.

Material of accessories

Accessories Bore size	Mounting accessories									Knuckle			
	LB	FA	FB	CA	CB	CR	SDB	FTC	TCM2	I	Y	F	U
12~25	△	●	●	●	-	-	△	■	●	□	□	□	□
32~100	△	●	●	◇	◇	◇	-	■	●	□	□	□	□
125	-	◇	◇	◇	◇	◇	-	■	●	□	□	□	□

●—Aluminum alloy; ■—Cast iron; ◇—Ductile Iron; △—SPCC; □—Carbon Steel

Dimensions

LB

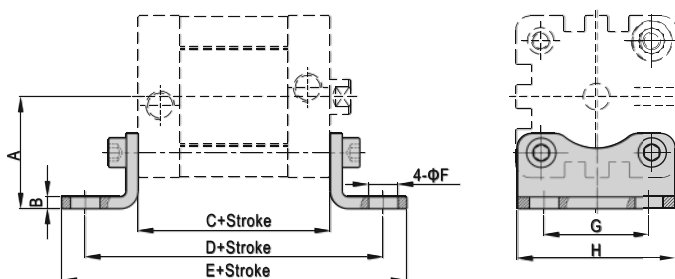

Bore size\Item	A	B	C	D	E	F	G	H
12	21	3	35	61	71	5.5	16	25
16	22	3	35	61	70.6	5.5	18	27
20	27	3.8	37	69	81.6	6.5	22	34
25	29	3.8	39	71	83.6	6.5	26	38
32	33.5	4	44	76	89	7	32	48
40	38	4	45.5	81.5	97.5	10	36	54
50	45	5	45.5	87.5	103.5	10	45	65
63	50	5	49	91	107	10	50	75
80	63	6	54	106	127	12	63	95
100	74	6	67	121	146	14.5	75	112

[Note] Valve C in the above table is only for ACE series. Please refer to relevant content for valve C of other series.



Compact cylinder



ACE Series—Accessories

FA/FB

Φ 12~ Φ 25

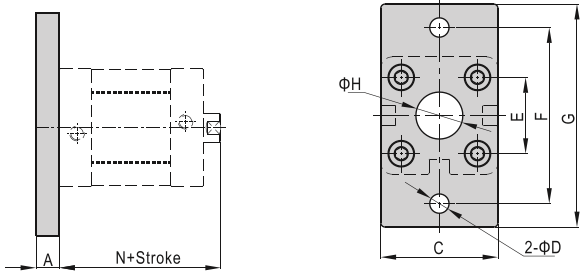

Φ 32~ Φ 125

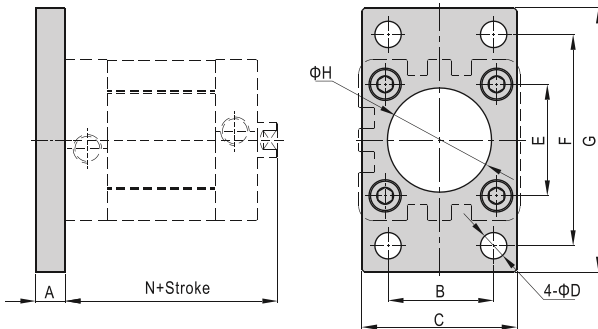

Bore size\Item	A	B	C	D	E	F	G	H	N
12	8	-	25	5.5	16	40	55	10	40
16	8	-	30	5.5	18	43	55	10	40
20	8	-	35	6.6	22	55	68	16	43
25	8	-	39.5	6.6	26	60	76	16	45
32	10	32	47	7	32.5	64	80	30.5	51
40	10	36	53	9	38	72	90	35.5	52.5
50	12	45	65	9	46.5	90	108	40.5	53.5
63	12	50	75	9	56.5	100	118	45.5	57
80	16	63	95	12.5	72	126	150	45.5	63
100	16	75	115	14.5	89	150	176	55.5	76
125	20	90	139	16.5	110	180	218	60.5	92

CA

Φ 12~ Φ 25

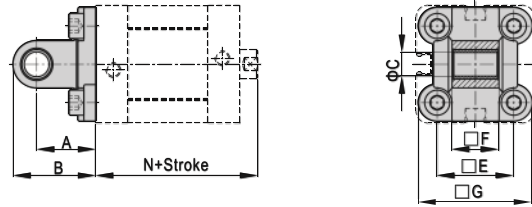

Φ 32~ Φ 125

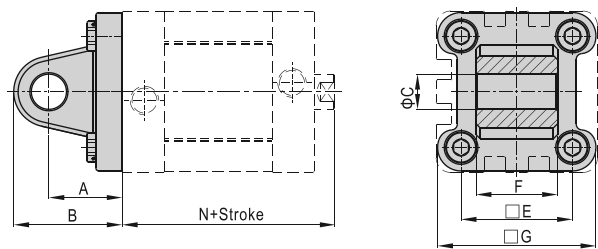

Bore size\Item	A	B	C	E	F	G	N
12	16	22	6	16	11.9	24	40
16	16	22	6	18	11.9	28.5	40
20	20	28	8	22	15.9	34.5	43
25	20	28	8	26	15.9	38.5	45
32	22	32.5	10	32.5	25.8	46.5	51
40	25	37	12	38	27.8	54	52.5
50	27	39	12	46.5	31.7	64	53.5
63	32	47	16	56.5	39.7	75	57
80	36	51.5	16	72	49.7	93	63
100	41	61	20	89	59.7	110	76
125	50	74	25	110	69.7	134	92

CB Φ 32~ Φ 125

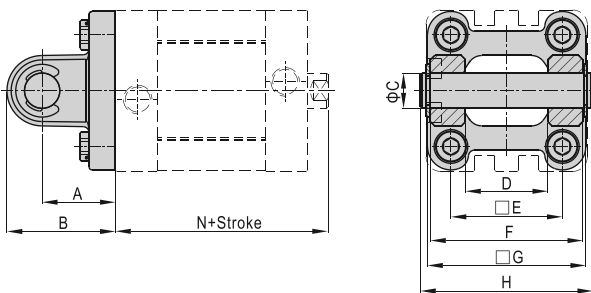

Bore size\Item	A	B	C	D	E	F	G	H	N
32	22	32.5	10	26	32.5	45	46.5	51	51
40	25	37	12	28	38	52	54	59	52.5
50	27	39	12	32	46.5	60	64	67	53.5
63	32	47	16	40	56.5	70	75	77	57
80	36	51.5	16	50	72	90	93	97	63
100	41	61	20	60	89	110	110	119	76
125	50	74	25	70	110	130	134	139	92

[Note] CB is attached with relevant PIN.

CR Φ 32~ Φ 125

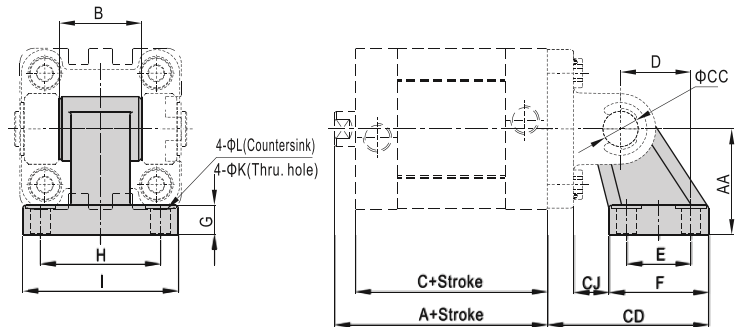

Bore size\Item	A	AA	B	C	CC	CD	CJ	D	E	F	G	H	I	K	L
32	51	32	26	44	10	50	10	21	18	31	8	38	51	6.6	11
40	52.5	36	28	45.5	12	56	12	24	22	35	10	41	54	6.6	11
50	53.5	45	32	45.5	12	68	13	33	30	45	12	50	65	9	14
63	57	50	40	49	16	77	17	37	35	50	12	52	67	9	14
80	63	63	50	54	16	93	19	47	40	60	14	66	86	11	17
100	76	71	60	67	20	106	22	55	50	70	15	76	96	11	17
125	92	90	70	81	25	135	26	70	60	90	20	94	124	14	20

[Note] CR can't be used alone, it must be used with CB.



Compact cylinder



ACE Series—Accessories

SDB $\Phi 12 \sim \Phi 25$

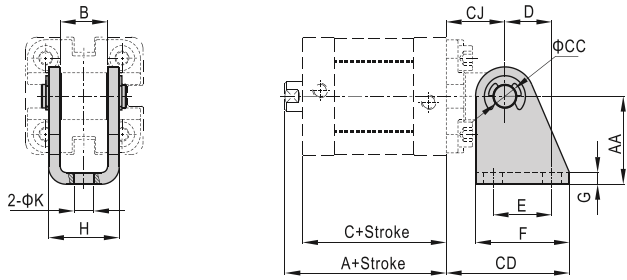

Bore size\Item	A	AA	B	C	CC	CD	CJ	D	E	F	G	H	K
12	40	27	12.1	35	6	34	16	13	15	25	2	18.1	5.5
16	40	27	12.1	35	6	34	16	13	15	25	2	18.1	5.5
20	43	30	16.1	37	8	42	20	16	20	32	2.5	24.1	6.6
25	45	30	16.1	39	8	42	20	16	20	32	2.5	24.1	6.6

[Note] SDB can't be used alone, it must be used with CA.

FTC $\Phi 32 \sim \Phi 125$

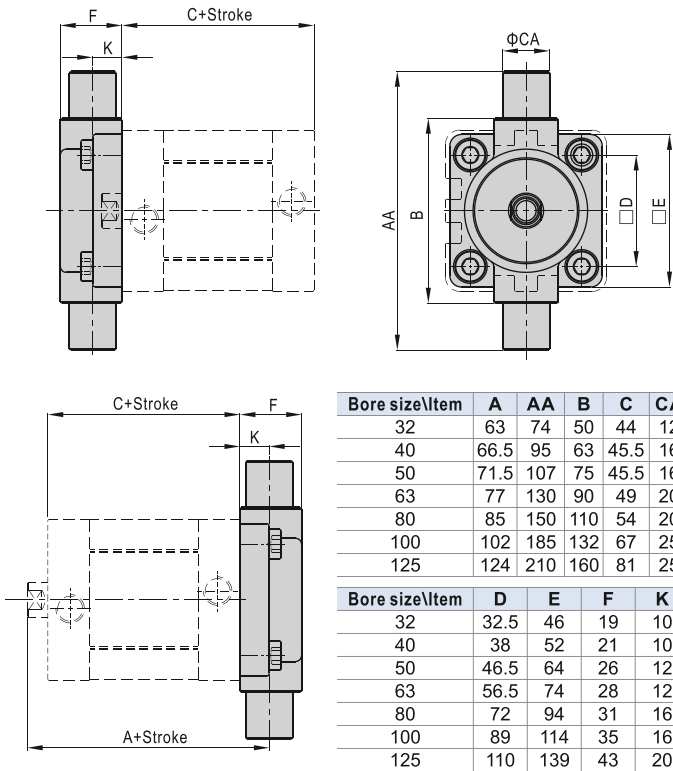

TCM2 $\Phi 32 \sim \Phi 125$

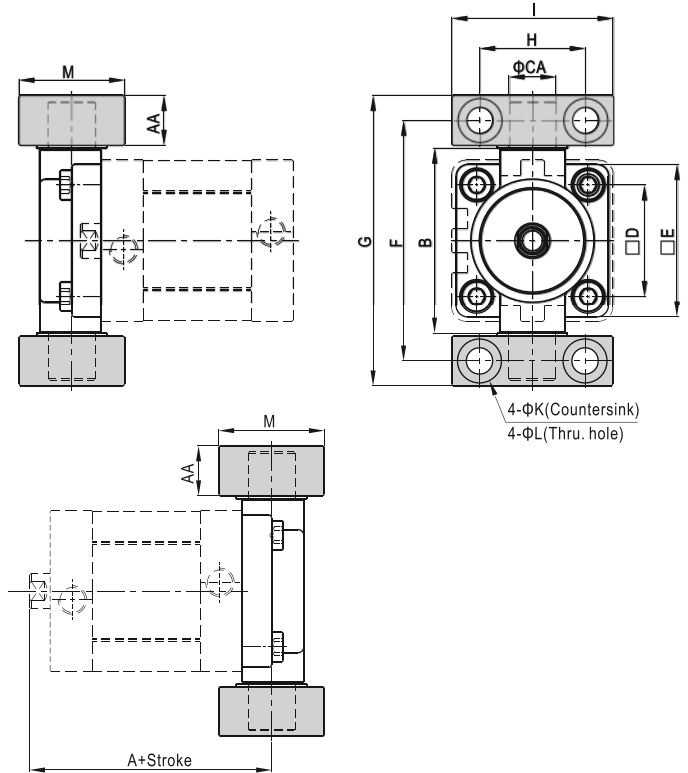

Bore size\Item	A	AA	B	CA	D	E	F	G	H	I	K	L	M
32	63	14	52	12	32.5	46	66	80	32	46	11	7	30
40	66.5	17	65	16	38	52	82	99	36	55	15	9	36
50	71.5	17	75	16	46.5	64	94	111	36	55	15	9	36
63	77	20.5	90	20	56.5	74	113.5	134	42	65	18	11	40
80	85	20.5	112	20	72	94	133.5	154	42	65	18	11	40
100	102	24.5	135	25	89	114	159.5	184	50	75	20	14	50
125	124	24.5	170	25	110	139	187.5	212	50	75	20	14	50

[Note] TCM2 can't be used alone, it must be used with FTC.
The installation position of the accessories can not be adjusted arbitrarily.

I Knuckle F-ACQ12I

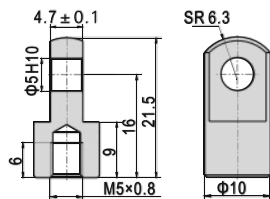

[Note] Other I knockles are common parts .
Please refer to P302 for knuckle detail,

Y Knuckle F-ACQ12Y

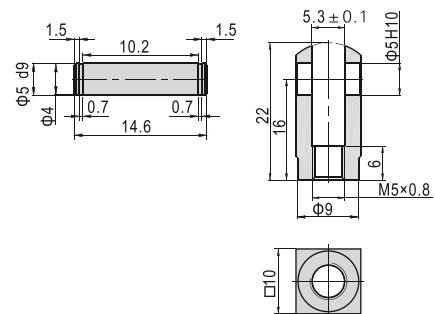

[Note] Other Y knockles are common parts .
Please refer to P303 for knuckle detail.

