

Air valve(3/2 way)



3A100 Series



Symbol

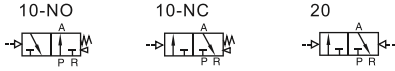

Product feature

- Structure in sliding column mode: good tightness and sensitive reaction.
- Double air control valves have memory function.
- Internal hole adopts special processing technology which has little attrition friction, low start pressure and long service life.
- No need to add oil for lubrication.
- Multi-mounting helps to install and apply.
- Integrate with the manifold to save installation space.

Specification

Model	3A110-M5	3A120-M5	3A110-06	3A120-06
Fluid	Air(to be filtered by 40 μ m filter element)			
Acting	Exterior control			
Port size [Note1]	M5		1/8"	
Orifice size	5.5mm ² (Cv=0.31)		12.0mm ² (Cv=0.67)	
Valve type	3 port 2 position			
Lubrication [Note2]	Not required			
Operating pressure	0.15~0.8MPa(21~114psi)			
Proof pressure	1.2MPa(175psi)			
Temperature	-20~70°C			
Material of body	Aluminum alloy			
Max. frequency [Note3]	5 cycle/sec			

[Note1] PT thread, G thread and NPT thread are available.

[Note2] Once lubricated air is used, continue with same medium to optimise valve life span. Lubricants like ISO VG32 or equivalent are recommended.

[Note3] The maximum actuation frequency is in the no-load state.

Ordering code

3A 1 10 06 NO □



1 Model	2 Code	3 Valve type	4 Port size	5 Acting type	6 Thread type
3A: Air Valve (3/2 way)	1: 100 Series	10: Single air control 20: Double air control	M5: M5 06: 1/8"	NC: Normally close NO: Normally open No this code	M5 Blank: PT G: G T: NPT

Please refer to 79 for manifold specification and the order way.

Flow chart

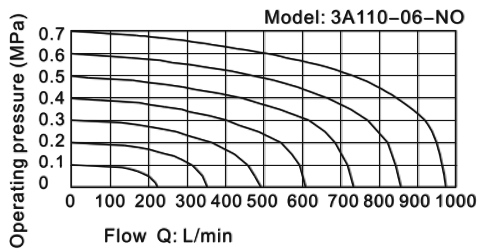

Inner structure

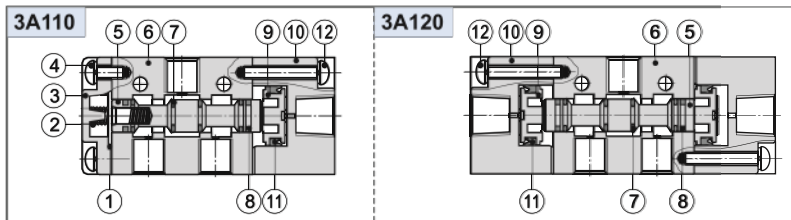

No.	Item	No.	Item	No.	Item
1	Bottom cover gasket	5	Spool	9	Piston
2	Spring	6	Body	10	Pilot body
3	Bottom cover	7	O-ring	11	Piston O-ring
4	Bottom cover screw	8	Wear ring	12	Piston screw

Dimension

3A110

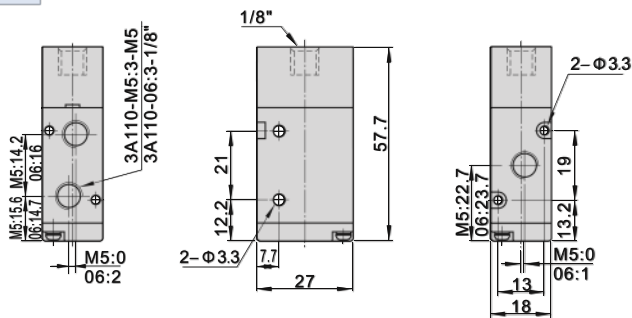

3A120

