

Fluid control valve(2/2 way)



2L Series (Direct-acting and normally closed)



Symbol



Product feature

1. Direct acting and normally closed type 2/2 way solenoid valve. Its high sensibility allows it to change direction quickly;
2. It has wide pressure range, including standard high pressure (H) to choose from;
3. It is compact, small size and light weight. It is easy to install and dismantle.
4. The valve body is made of SUS304 . Its coil has a Heat resistance classification of Class H. The standard seal material is PTFE(Teflon) which is suitable for a variety of working medium such as water with high temperature and vapour.
5. The protection class of the coil is IP65 and there is a choice for grommet or terminal electrical entry .

Specification

Model\Item	Port size [Note1]	Orifice size (Φmm)	Cv	Valid area or section (mm ²)	Weight [Note2](g)	Max. operating pressure differential		Proof pressure	
						MPa	psi	MPa	psi
2LH030	-06 1/8"	2.0	0.18	3.0	300	2.0	300	3.0	450
	-08 1/4"								
2L030	-06 1/8"	3.0	0.33	6.0	290	1.0	150		
	-08 1/4"								
2LH050	-10 3/8"	4.0	0.55	10.0	600	2.0	300		
	-15 1/2"								
2L050	-10 3/8"	5.0	0.83	15.0	600	1.0	150		
	-15 1/2"								

[Note1] PT thread, G thread and NPT thread are available.

[Note2] The weight in the table is the terminal valve's weight, 2L030 series grommet valve's weight is 10g less than terminal's. 2L050series grommet valve's weight is 20g less than terminal's.

Specification of coil

Valve type	Coil type	Power type	Frequency (Hz)	Voltage range	Electrical entry	Power Consumption (VA/W)	Insulation	Temp. rise(°C)	
2L□030	CDA116 CLA116	AC	50	± 15%	Terminal (CDA)	10.0VA	Class H	35	
			60			8.0VA		30	
		DC	-	± 10%		6.5W		30	
2L□050	CDA170 CLA170	AC	50	± 15%	Grommet (CLA)	25.0VA		Class H	60
			60			22.0VA			55
		DC	-	± 10%		10.5W			40

Inner structure

2L030 (Terminal)

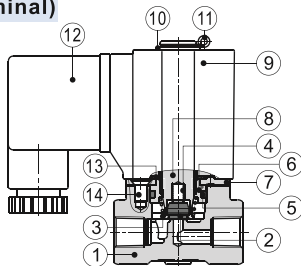

No.	Item	No.	Item	No.	Item
1	Body	6	Fixed cap	11	E Clip
2	Airtight ring	7	Fixed plate	12	Connector
3	Spring	8	Movable core	13	Bead flange
4	Spring	9	Coil assembly	14	Screw
5	O-ring	10	Washer		

Valve's specification

Acting	Direct acting				
	Initial state	Normally closed			
Adaptable fluid [Note1]	Steam, High temperature Water, Oil				
Viscosity limit	Under 20CST				
Ambient and fluid temperature (°C)		Oil	Water	Steam	Ambient
	Max.	150	150	183	100
	Min.	-10 [Note2]	1	-	-20

[Note1] Please refer to P145 for detail of other's fluid;

[Note2] 50CST or less.

Ordering code

Ordering code of valves

2L H 030 08 A □ □

① ② ③ ④ ⑤ ⑥ ⑦

① Model	② Pressure condition	③ Size series	④ Port size	⑤ Voltage	⑥ Electrical entry	⑦ Thread type
2L: 2/2 way direct-acting and normally closed	H: High pressure Blank: Standard	030: 030 Series	06: 1/8" 08: 1/4"	A: AC220V B: DC24V C: AC110V E: AC24V F: DC12V	Blank: Terminal I: Grommet	Blank: PT G: G T: NPT
		050: 050 Series	10: 3/8" 15: 1/2"			

Ordering code of accessories

Ordering code of accessories is the same as 2S series valve's, Please refer to P120 for details of ordering code.



Fluid control valve(2/2 way)

2L Series (Direct-acting and normally closed)



Flow chart

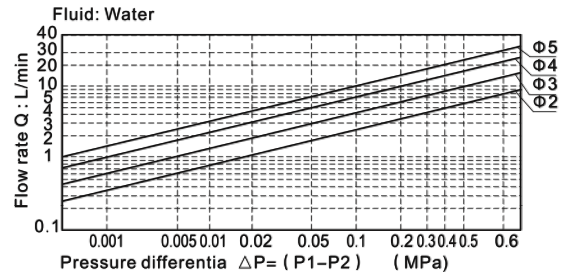
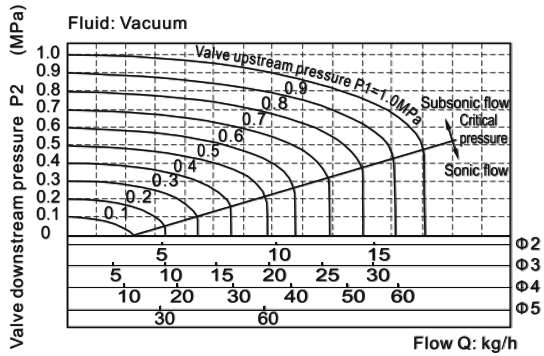

Dimensions

2L□030(Terminal)

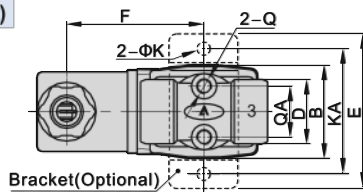

Bracket(Optional)

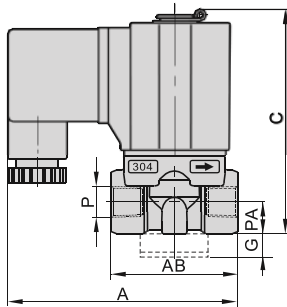

2L□030(Grommet)

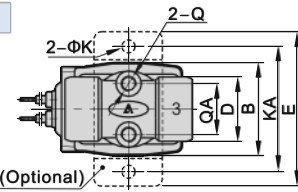

Bracket(Optional)

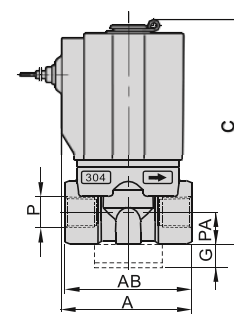

2L□050(Terminal)

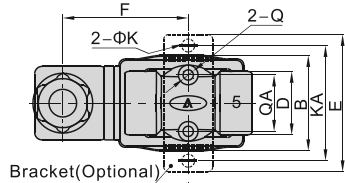

Bracket(Optional)

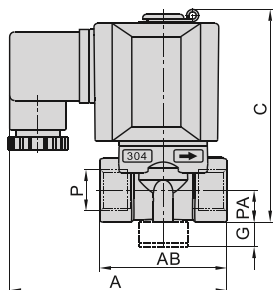

2L□050(Grommet)

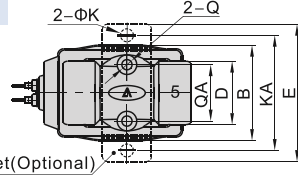

Bracket(Optional)

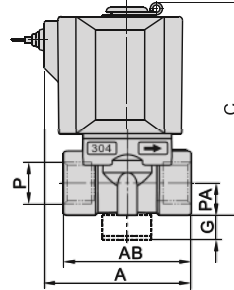

Model/Item	A	AB	B	C	D	E	F	G	K	KA	P	PA	Q	QA
2L□030-06	72.5	40	29.5	71	20	49	43.5	10	5.3	40	1/8"	10	M5	16
2L□030-08	72.5	40	29.5	71	20	49	43.5	10	5.3	40	1/4"	10	M5	16
2L□050-10	89.5	52	39	87	26	56	51	10	5.3	48	3/8"	13	M5	23
2L□050-15	89.5	52	39	87	26	56	51	10	5.3	48	1/2"	13	M5	23

Model/Item	A	AB	B	C	D	E	G	K	KA	P	PA	Q	QA
2L□030-06	41	40	29.5	71	20	49	10	5.3	40	1/8"	10	M5	16
2L□030-08	41	40	29.5	71	20	49	10	5.3	40	1/4"	10	M5	16
2L□050-10	60	52	39	87	26	56	10	5.3	48	3/8"	13	M5	23
2L□050-15	60	52	39	87	26	56	10	5.3	48	1/2"	13	M5	23



Fluid control valve(2/2 way)



2L Series (Internally piloted and normally closed)



Symbol



Product feature

1. Indirect acting (Internal pilot) and normally closed type 2/2 way solenoid valve. Its high sensibility allows it to change direction quickly.
2. It is compact, small size and light weight. It is easy to install and dismantle.
3. The valve body is made of SUS304. Its coil has a Heat resistance classification of Class H. The standard seal material is PTFE (Teflon) which is suitable for a variety of working medium such as water with high temperature and vapour.
4. The protection class of the coil is IP65 and there is a choice for grommet or terminal electrical entry.

Inner structure

2L150(Grommet)

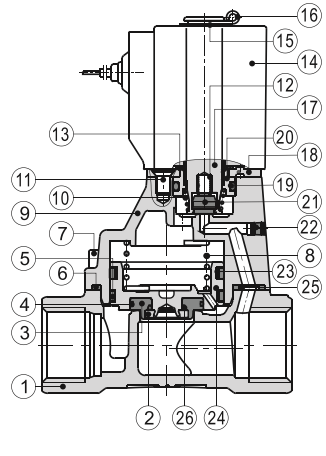

No.	Item
1	Body
2	Fixed ring
3	Airtight bush
4	O-ring
5	Wear ring
6	Gasket
7	Screw
8	Spring
9	Cover
10	Spring
11	Screw
12	Spring
13	Bead flange
14	Coil assembly
15	Washer
16	E Clip
17	Movable core
18	Fixed plate
19	O-ring
20	Fixed cap
21	Airtight ring
22	Plug
23	Spring
24	Piston
25	Bushing
26	O-ring

Specification

Model\Item	Port size [Note1]	Orifice size (Ømm)	Cv	Valid area or section (mm ²)	Weight [Note2](g)	Operating pressure differential		Proof pressure	
						MPa	psi	MPa	psi
2L150-15	1/2"	15.0	5.50	100.0	675	Max: 1.0 Min: 0.05	Max: 150 Min: 10	1.5	220
2L200-20	3/4"	20.0	9.50	170.0	875				
2L250-25	1"	25.0	12.50	220.0	1120				
2L320-32	1 1/4"	35.0	23.00	420.0	2700				
2L400-40	1 1/2"	40.0	31.00	560.0	3250				
2L500-50	2"	50.0	49.00	880.0	4300				

[Note1] PT thread, G thread and NPT thread are available.

[Note2] The weight in the table is the terminal valve's weight, 2L150~250series grommet valve's weight is 10g less than terminal's. 2L320~500series grommet valve's weight is 20g less than terminal's.

Specification of coil

Valve type	Coil type	Power type	Frequency (Hz)	Voltage range	Electrical entry	Power Consumption (VA/W)	Insulation	Temp. rise(°C)
2L150	CDA116 CLA116	AC	50	± 15%	Terminal (CDA)	10.0VA	Class H	35
2L200			60			8.0VA		30
2L250		DC	-	± 10%		6.5W		30
2L320	CDA170 CLA170	AC	50	± 15%	Grommet (CLA)	25.0VA		60
2L400			60			22.0VA		55
2L500		DC	-	± 10%		10.5W	40	

Valve's specification

Acting	Internally piloted				
	Initial state	Normally closed			
Adaptable fluid [Note1]	Steam, High temperature Water, Oil				
Viscosity limit	Under 20CST				
Ambient and fluid temperature (°C)		Oil	Water	Steam	Ambient
	Max.	150	150	183	100
	Min.	-10 [Note2]	1	-	-20

[Note1] Please refer to P145 for detail of other's fluid;
[Note2] 50CST or less.

Ordering code

Ordering code of valves

2L 150 15 A □ □
① ② ③ ④ ⑤ ⑥

① Model	② Orifice size	③ Port size	④ Voltage	⑤ Electrical entry	⑥ Thread type
2L: 2/2 way internally piloted and normally closed	150: Ø15mm	15: 1/2"	A: AC220V B: DC24V C: AC110V E: AC24V F: DC12V	Blank: Terminal I: Grommet	Blank: PT G: G T: NPT
	200: Ø20mm	20: 3/4"			
	250: Ø25mm	25: 1"			
	320: Ø35mm	32: 1 1/4"			
	400: Ø40mm	40: 1 1/2"			
	500: Ø50mm	50: 2"			

Ordering code of accessories

Ordering code of accessories is the same as 2S series valve's, please refer to P122 for details of ordering code.

[Note] 320\400\500 series valves do not have mounting accessories.



Fluid control valve(2/2 way)



2L Series (Internally piloted and normally closed)

Flow chart

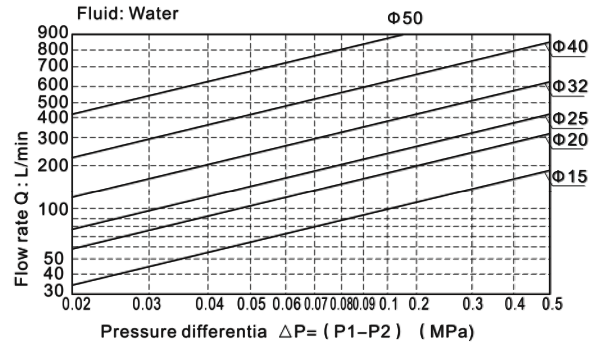
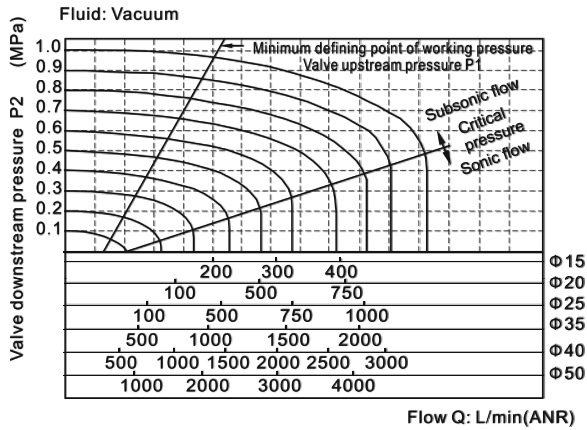

Dimensions

2L150~250(Terminal)

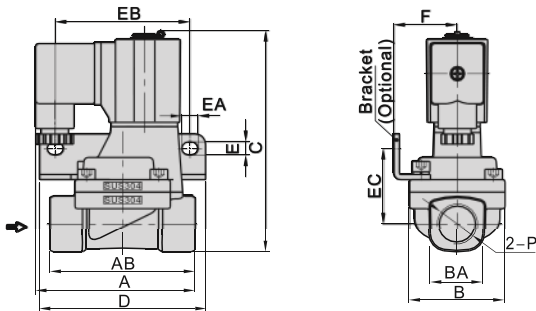

2L150~250(Grommet)

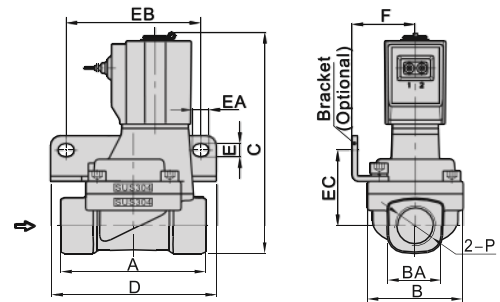

2L320~500(Terminal)

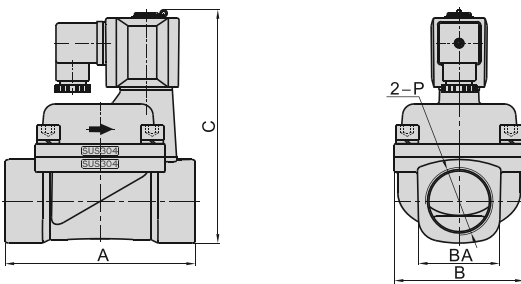

2L320~500(Grommet)

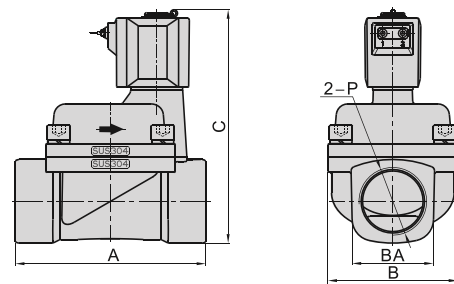

Model/Item	A	AB	B	BA	C	D	E	EA	EB	EC	F	P
2L150-15	77	70	46	27.5	107	80	6.4	8	65	36.5	30.5	1/2"
2L200-20	78.5	82	53	33.5	115.5	90	6.4	8	75	40	34	3/4"
2L250-25	81	92	59	40.5	124	95	6.4	8	80	44.5	36	1"
2L320-32	125	-	80	52	154	-	-	-	-	-	-	1 1/4"
2L400-40	132	-	90	58	162	-	-	-	-	-	-	1 1/2"
2L500-50	150	-	100	70	177	-	-	-	-	-	-	2"

Model/Item	A	B	BA	C	D	E	EA	EB	EC	F	P
2L150-15	70	46	27.5	107	80	6.4	8	65	36.5	30.5	1/2"
2L200-20	82	53	33.5	115.5	90	6.4	8	75	40	34	3/4"
2L250-25	92	59	40.5	124	95	6.4	8	80	44.5	36	1"
2L320-32	125	80	52	154.5	-	-	-	-	-	-	1 1/4"
2L400-40	132	90	58	162	-	-	-	-	-	-	1 1/2"
2L500-50	150	100	70	177	-	-	-	-	-	-	2"

