

Fluid control valve(2/2way)



2W Series (Direct-acting and normally closed)



Symbol



Product feature

1. Direct acting and normally closed type 2/2 way solenoid valve. Its high sensibility allows it to change direction quickly;
2. It has wide pressure range, including extra high pressure (X), high pressure (H), standard, large volume(L) and extra large volume (T) to choose from;
3. It is compact, small size and light weight. It is easy to install and dismantle.
4. The valve body is made of brass. Its coil has a Heat resistance classification of Class B. The standard seal material is FPM-F. Please contact us if other material are required.
5. The protection class of the coil is IP65 and there is a choice for grommet or terminal electrical entry.

Inner structure

2W030 (Terminal)

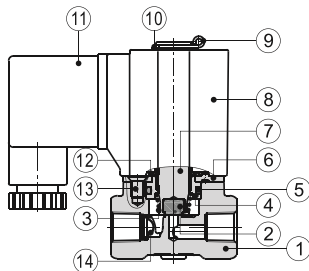

No.	Item	No.	Item
1	Body	8	Coil assembly
2	Airtight ring	9	E Clip
3	Spring	10	Gasket
4	Fixed cap	11	Connector
5	O-ring	12	Washer
6	Fixed plate	13	Screw
7	Movable core	14	Filter [Note]

[Note] Extra large volume type has no filter element.

Specification

Model\Item	Port size [Note1]	Orifice size (Φmm)	Cv	Valid area or section (mm ²)	Weight [Note2](g)	Max. operating pressure differential		Proof pressure	
						MPa	psi	MPa	psi
2WX030	-06 1/8"	1.5	0.10	1.8	305	3.0	450	5.0	750
	-08 1/4"				295				
2WH030	-06 1/8"	2.0	0.18	3.0	305	2.0	300		
	-08 1/4"				295				
2W030	-06 1/8"	3.0	0.33	6.0	305	1.0	150		
	-08 1/4"				295				
2WL030	-06 1/8"	4.0	0.55	10.0	305	0.5	75		
	-08 1/4"				295				
2WT030	-06 1/8"	6.0	1.10	12.0	305	0.1	15		
	-08 1/4"				295				
2WX050	-10 3/8"	3.0	0.34	6.1	620	3.0	450		
	-15 1/2"				600				
2WH050	-10 3/8"	4.0	0.55	10.0	620	2.0	300		
	-15 1/2"				600				
2W050	-10 3/8"	5.0	0.83	15.0	620	1.0	150		
	-15 1/2"				600				
2WL050	-10 3/8"	7.0	1.40	25.0	620	0.5	75		
	-15 1/2"				600				
2WT050	-10 3/8"	10.0	2.20	40.0	620	0.1	15		
	-15 1/2"				600				

[Note1] PT thread, G thread and NPT thread are available.

[Note2] The weight in the table is the terminal valve's weight, 2W030 series grommet valve's weight is 10g less than terminal's. 2W050series grommet valve's weight is 20g less than terminal's.

Specification of coil

Valve type	Coil type	Power type	Frequency (Hz)	Voltage range	Electrical entry	Power Consumption (VA/W)	Insulation	Temp. rise(°C)		
2W□030	CDA116 CLA116	AC	50	± 15%	Terminal (CDA)	10.0VA	Class B	35		
			60			8.0VA		30		
2W□050	CDA170 CLA170	AC	50	± 15%		Grommet (CLA)		6.5W	Class B	30
			60					25.0VA		60
		DC	-	± 10%			10.5W			55
										40

Valve's specification

Acting		Direct acting				
Initial state		Normally closed				
Adaptable fluid [Note1]		Air, Water, Oil				
Viscosity limit		Under 20CST				
Ambient and fluid temperature (°C)		Water		Air	Oil	Ambient
		Max.	80	90	80	70
		Min.	1	-20 [Note2]	-10 [Note3]	-20

[Note1] Please refer to P145 for detail of other's fluid;

[Note2] Dew point: -20(°C) or less;

[Note3] 50CST or less.

Ordering code

Ordering code of valves

2W L 030 08 A □ □



① Model	② Pressure condition	③ Size series	④ Port size	⑤ Voltage	⑥ Electrical entry	⑦ Thread type
2W: 2/2 way direct-acting and normally closed	X: Extra high pressure H: High pressure Blank: Standard	030: 030 Series	06: 1/8" 08: 1/4"	A: AC220V B: DC24V C: AC110V E: AC24V F: DC12V	Blank: Terminal I: Grommet	Blank: PT G: G T: NPT
	L: Large volume T: Extra large volume	050: 050 Series	10: 3/8" 15: 1/2"			

Ordering code of accessories

Ordering code of accessories is the same as 2S series valve's, Please refer to P120 for details of ordering code.



Fluid control valve(2/2way)



2W Series (Direct-acting and normally closed)

Flow chart

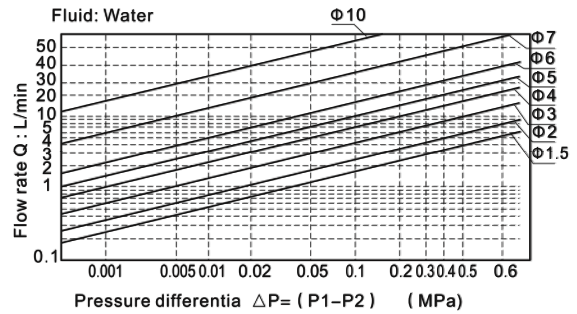
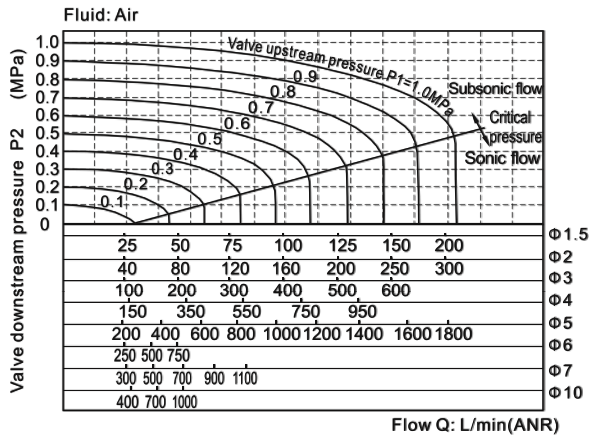

Dimensions

2W□030 (Terminal)

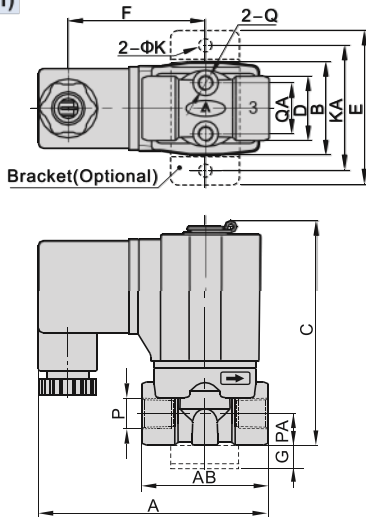

2W□030 (Grommet)

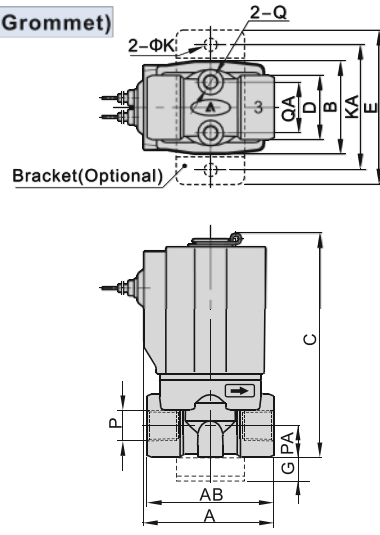

2W□050 (Terminal)

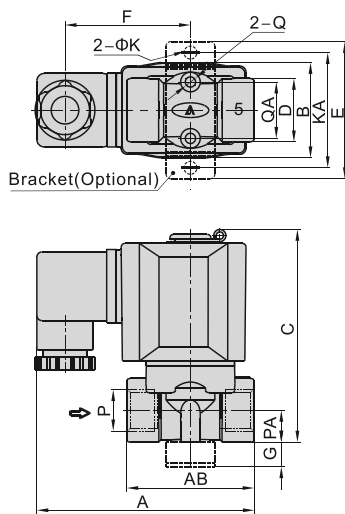

2W□050 (Grommet)

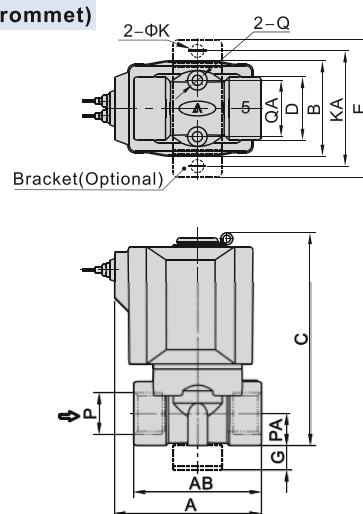

Model\Item	A	AB	B	C	D	E	F	G	K	KA	P	PA	Q	QA
2W□030-06	72.5	40	29.5	71	20	49	43.5	10	5.3	40	1/8"	10	M5	16
2W□030-08	72.5	40	29.5	71	20	49	43.5	10	5.3	40	1/4"	10	M5	16
2W□050-10	89.5	52	39	87	26	56	51	10	5.3	48	3/8"	13	M5	23
2W□050-15	89.5	52	39	87	26	56	51	10	5.3	48	1/2"	13	M5	23

Model\Item	A	AB	B	C	D	E	G	K	KA	P	PA	Q	QA
2W□030-06	41	40	29.5	71	20	49	10	5.3	40	1/8"	10	M5	16
2W□030-08	41	40	29.5	71	20	49	10	5.3	40	1/4"	10	M5	16
2W□050-10	60	52	39	87	26	56	10	5.3	48	3/8"	13	M5	23
2W□050-15	60	52	39	87	26	56	10	5.3	48	1/2"	13	M5	23



Fluid control valve(2/2way)



2W Series (Internally piloted and normally closed)



Symbol



Product feature

1. Indirect acting (Internal pilot) and normally closed type 2/2 way solenoid valve. Its can change direction quickly and has large flow.
2. It is compact, small and light weight. It is easy to install and dismantle;
3. The valve body is made of brass. The coil has a Heat resistance classification of Class B. The standard seal material is FPM-F. Please contact us if other material are required.
4. The protection class of the coil is IP65 and there is a choice for grommet or terminal electrical entry.

Specification

Model\Item	Port size [Note1]	Orifice size (Φmm)	Cv	Valid area or section (mm ²)	Weight [Note2](g)	Operating pressure differential		Proof pressure	
						MPa	psi	MPa	psi
2W150-15	1/2"	15.0	5.50	100.0	720	Max: 1.0 Min: 0.05	Max: 150 Min: 10	1.5	220
2W200-20	3/4"	20.0	9.50	170.0	950				
2W250-25	1"	25.0	12.5	220.0	1200				

[Note1] PT thread, G thread and NPT thread are available.

[Note2] The weight in the table is the terminal valve's weight, grommet valve's weight is 10g less than terminal's.

Specification of coil

Valve type	Coil type	Power type	Frequency (Hz)	Voltage range	Electrical entry	Power Consumption (VA/W)	Insulation	Temp. rise(°C)
2W150	CDA116	AC	50	± 15%	Terminal (CDA)	10.0VA	Class B	35
2W200	CLA116		60			8.0VA		30
2W250		DC	-	± 10%	Grommet (CLA)	6.5W		30

Valve's specification

Acting		Internally piloted			
Initial state		Normally closed			
Adaptable fluid [Note1]		Air, Water, Oil			
Viscosity limit		Under 20CST			
Ambient and fluid temperature (°C)		Water	Air	Oil	Ambient
	Max.	80	90	80	70
	Min.	1	-20 [Note2]	-10 [Note3]	-20

[Note1] Please refer to P145 for detail of other's fluid;

[Note2] Dew point: -20(°C) or less; [Note3] 50CST or less.

Inner structure

2W150 (Grommet)

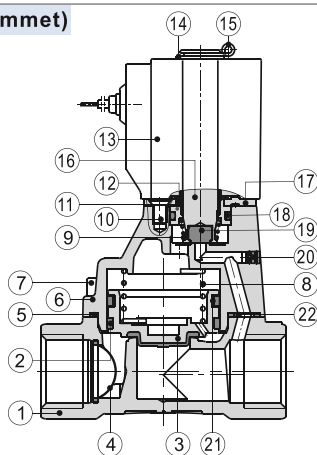

No.	Item	No.	Item	No.	Item
1	Body	9	Spring	16	Movable core
2	Filter	10	Screw	17	Fixed plate
3	Piston	11	Fixed cap	18	O-ring
4	Wear ring	12	Washer	19	Airtight ring
5	O-ring	13	Coil assembly	20	Plug
6	Cover	14	Washer	21	Spring
7	Screw	15	E Clip	22	Spacer
8	Spring				

Ordering code

Ordering code of valves

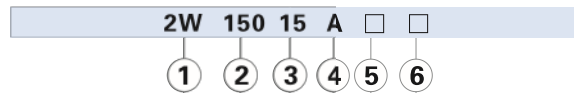

① Model	② Orifice size	③ Port size	④ Voltage	⑤ Electrical entry	⑥ Thread type
2W: 2/2 way internally piloted and normally closed	150: Φ15mm	15: 1/2"	A: AC220V B: DC24V C: AC110V E: AC24V F: DC12V	Blank: Terminal I: Grommet	Blank: PT G: G T: NPT
	200: Φ20mm	20: 3/4"			
	250: Φ25mm	25: 1"			

Ordering code of accessories

Ordering code of accessories is the same as 2S series valve's, Please refer to P122 for details of ordering code.

[Note] 320\400\500 series valves do not have mounting accessories.



Fluid control valve(2/2way)



2W Series (Internally piloted and normally closed)

Flow chart

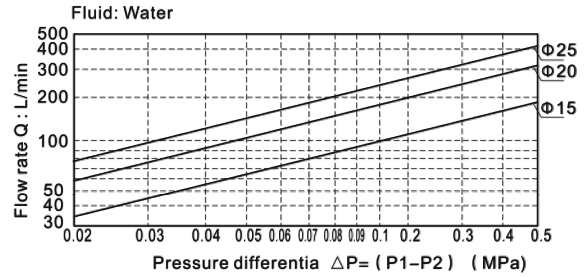
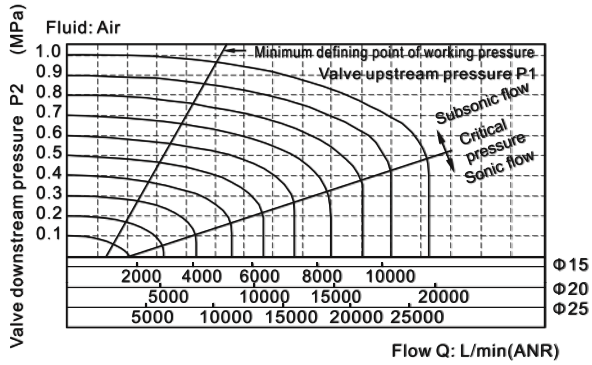

Dimensions

Terminal

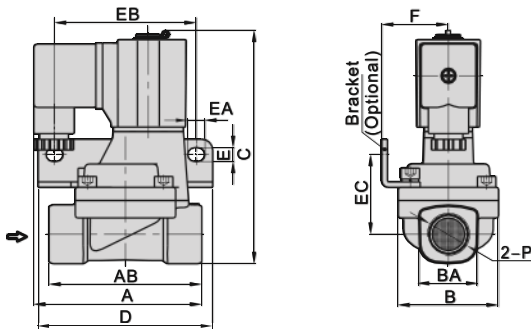

Model\Item	A	AB	B	BA	C	D	E	EA	EB	EC	F	P
2W150-15	77	70	46	27.5	107	80	6.4	8	65	36.5	30.5	1/2"
2W200-20	78.5	82	53	33.5	115.5	90	6.4	8	75	40	34	3/4"
2W250-25	81	92	59	40.5	124	95	6.4	8	80	44.5	36	1"

Grommet

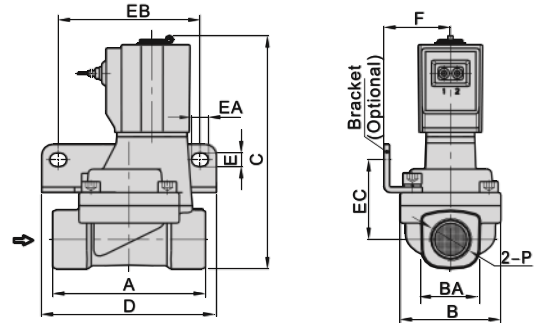

Model\Item	A	B	BA	C	D	E	EA	EB	EC	F	P
2W150-15	70	46	27.5	107	80	6.4	8	65	36.5	30.5	1/2"
2W200-20	82	53	33.5	115.5	90	6.4	8	75	40	34	3/4"
2W250-25	92	59	40.5	124	95	6.4	8	80	44.5	36	1"

